



MASTERLOAD.iQ™

Setup and Operations Manual



LIQUID CONTROLS®

An IDEX Energy & Fuels Business

Table of Contents

Resources in this Guide	3
Register Overview	4
Publication Updates	5
Safety Procedures	6
Specifications	8
Regulatory & Certifications	12
Check for a Good Ground	16
FCC Compliance	17
Dimensions - Panel Mount	19
Dimensions - Meter Mount	22
Setup and Operation	23
Software License Agreement	27
Operational Information & Main Menu	28
Delivery Screen Layouts	29
Display Screen Types	30
Keypad Interface	33
Delivery Details	38
Diagnostics	48
Setup Menu	57
Operating the Register	109
Appendix A: K-Factor (Pulse/Unit) Chart	133
Appendix B: Data Types	133

LCR.iQ Register

Congratulations on ownership of the new LCR.iQ electronic meter register and controller. This manual provides the technical details on installation, hardware, setup, operation, and regulatory information for your register.

NOTE: Throughout this manual, LCR.iQ is referred to as “Register” (unless otherwise specifically referenced by name).

The Register calculates, monitors and records volumetric data from bulk flow meters, provides fluid transfer process customization and automation, ties in critical system sensors and inputs, and bridges data communication between the operator, the equipment, and the operator’s back office if necessary.

The Register is specially designed to work with leading bulk fuel meters such as LC and Avery-Hardoll, but will easily retrofit into existing systems with other flow meter brands.

The Register provides many new features, yet supports backward compatibility with LCR-II and LCR-600.



Resources in this Guide

You can easily download PDF editions of the Installation Guide, Setup and Operations Guide, and wiring diagrams by clicking the links below.

Otherwise, you may prefer to start with the [Register Overview](#)⁴, or proceed directly to browse both the [Installation Guide](#) and the [Setup and Operation Guide](#).

Adobe PDF Guides

Download either of the guides using the links below:

- [Installation Guide](#)
- [SPANISH Installation Guide](#)
- [Setup and Operations Guide](#)

Wiring Diagrams

Download a high-resolution PDF edition of these wiring diagrams:

- **Rev E board** - Download the [full-size wiring diagram](#).
- **Rev J board** - Download the [full-size wiring diagram](#).

Register Overview

The Register is a microprocessor-based electronic meter register that can be used for Weights & Measures approved custody transfer actions in mobile or fixed installations. The Register is a self-contained unit. All operation, setup, and configuration functions can be carried out using the Register function keys and alphanumeric keypad. No lap pads, laptops, or other data entry devices are required.

A complete Liquid Controls meter system not only accurately measures product, it also regulates product flow and removes contaminants in order to produce the optimal conditions for measurement. Typical systems include an vapor/vapor eliminator, strainer, meter, register, and control valve.

Basic Functions

The principle functions of the Register registers include:

- Weights & Measures custody transfer (product delivery and ticket generation)
- Metrological data collection
- Preset deliveries by volume
- Multiple product selection
- Multi-point meter calibration
- Security settings
- Air and vapor elimination (with proper accessories)
- Single and dual stage valve control (with proper accessories)
- Electronic Temperature Volume Compensation (ETVC)

Publication Updates

The most current versions of all Liquid Controls publications are available on our web site, www.LCmeter.com/resources/technical/manuals. If there are questions about the language or interpretation of any LC manuals, instructions, or specification sheets, please first contact your local distributor for help with your inquiry.

For service related issues that require further support from the Liquid Controls Service Team, please call the number below.

Liquid Controls Corporate Office:

Phone: +1 847 295-1050

Toll-free: 800 458 5262

Address: Liquid Controls LLC, 105 Albrecht Drive, Lake Bluff, IL 60044 USA

Website: www.LCmeter.com

Safety Procedures



BE PREPARED

- Before using this product, read and understand the instructions.
- All work must be performed by qualified personnel trained in the proper application, installation, and maintenance of equipment and/or systems in accordance with all applicable codes and ordinances.
- When handling electronic components/boards, always use proper Electrostatic Discharge (ESD) equipment and follow proper procedures.
- Make sure that all necessary safety precautions have been taken.
- Provide for proper ventilation, temperature control, fire prevention, evacuation, and fire management.
- Provide easy access to appropriate fire extinguishers for your product.
- Consult with your local fire department, state, and local codes to ensure adequate preparation.
- Read this manual and all the literature provided in your owner's packet.
- Save these instructions for future reference.
- Failure to follow the instructions in this publication could result in, personal injury, or death from fire and/or explosion, property damage, or other hazards that may be associated with this type of equipment.



SAFELY EVACUATE PIPING SYSTEM

Before disassembly of any meter or accessory component: **ALL INTERNAL PRESSURES MUST BE RELIEVED AND ALL LIQUID DRAINED FROM THE SYSTEM IN ACCORDANCE WITH ALL APPLICABLE PROCEDURES.**

- Pressure must be 0 (zero) psi.
- Close all liquid and vapor lines between the meter and liquid source.

Failure to follow this warning could result in property damage, personal injury, or death from fire and/or explosion, or other hazards that may be associated with this type of equipment.



OBSERVE NATIONAL & LOCAL CODES

Power, input, and output (I/O) wiring must be in accordance with the area classification for which it is used (Class I, Div 2). For North America, installations must be per the U. S. National Electrical Code, NFPA 70, or the Canadian Electrical Code in order to maintain Class I, Division 2 ratings. This may require using connections or other adaptations in accordance with the requirements of the authority having jurisdiction.

Peripheral equipment must be suitable for the hazardous location where it is installed. (L'équipement périphérique doit être adapté à la zone dangereux où il est installé.)

WARNING: Explosion Hazard

When in hazardous locations, turn power OFF before replacing or wiring modules. (Lorsque dans des endroits dangereux, coupler le courant avant de remplacer ou de câbler des modules.)

DO NOT disconnect equipment unless power has been switched OFF or the area is known to be Non-Hazardous. (NE PAS déconnecter l'équipement sans coupler l'alimentation ou sans s'assurer que la zone est non dangereuse.)

WARNING: Use 3.5 in • lb (0.4 N • m) torque when tightening terminal block screws.

Preventing ESD Damage

To prevent electrostatic discharge (ESD) damage, truck installations must properly ground the truck seat cushion and the Epson printer chassis. Prolonged exposure to ESD over weeks, months, or years can corrupt register memory and damage the electronic components in Register registers (as well as other electrical components in the truck electrical system).

Adjustable, shock-absorbing seats, if not grounded correctly, generate significant amounts of ESD. The pivots and hinges of these seats isolate the seat cushion from an electrical ground. Without proper bonding, static electric charge builds between the seat cushion and the

operator. This electric charge can enter the Register from any point in the truck electrical system, including register power and printer cabling.

Specifications

Mechanical

Housing and Keypad

The Register housing and bases are aluminum castings that are powder-coated with high durability, urethane powder. The cover internal hinge design provides easy access to the internal connections and keeps all moving hinge parts out of the elements to further prevent corrosion. Weights and Measures features are accessible by using a seal-able fastener on the side of the cover.

Construction Materials

- High grade A360 Die Cast Aluminum, enclosure cover, and enclosure base
- Chromate finish with powder-coat protective coating
- Tempered glass display window
- Silicone display glass seal
- Stainless steel display bracket
- Silicone door seal
- Keypad – Membrane Switch with silicone overlay
- Stainless steel fasteners/hardware
- Stainless steel bonded silicone sealing washer

Certified Operational Temperature Rating

- The Register is certified for normal operation within the temperature range of -40 to 140 °F (-40 to 60 °C).

Display

- 7 inch heavy duty, high definition TFT/LCD (Thin Film Transistor Liquid Crystal Display) video display with LED backlight unit.

- 800 x 480 pixels (152.4 mm x 91.4 mm)
- Luminance: 1500 (cd/m²)
- Display acceptable operation or storage temperature -40 °F to 185 °F (-40 °C to 85 °C).

Weight

- Approximately 14 lbs / 6.5 kgs (no added accessories)

Cable Entry

- Ten (10), 1/2-inch NPT (1/2-14 NPT) threaded ports

Alphanumeric Keypad

The Register alphanumeric keypad is made of petroleum resistant silicone and consists of 12 large alpha-numeric keys, 5 navigation keys, and 5 function keys that relate to the adjacent display indicators for operator-guided functionality. The keys, when pressed, give the operator a tactile, positive confirmation of keystrokes. The keypad multi-tap functionality also allows users to input up to four alpha-numeric characters on a single key.

Electrical

Inputs

Inputs are configurable in the Register to handle a variety of external accessories that provide data signals in the metering system including pulse input and a variety of external sensors.

Register Input Voltage

- Voltage – 9 to 28 VDC
- Current maximum: 5 A maximum

Pulse Input

In order to calculate flow measurements when mounted to a positive displacement meter, the Register receives a pulse input from a quadrature pulser that is mechanically connected to the

flow meter output shaft (meter mount option only). A pulse input can also come from an external device such as a Liquid Controls Pulse Output Device (POD) or another externally mounted pulse generator. If an external LC POD is purchased, these materials are necessary, but are not supplied with the POD:

- 16-22 AWG 4 conductor Shielded Cable (Consult the POD manual for complete specifications)
- Weather Proof flexible conduit or loom
- ½" Conduit connectors or cable glands

RTD Temperature Probe

The Register is equipped with an input for a temperature probe, so the register can read realtime temperature as well as compensate volume measurements according to the temperature of the product.

- 4 wire platinum sensor
- 100 Ω resistance at 0 °C
- 138.5 Ω resistance at 100 °C

Optical Air Eliminator

The Register is equipped to handle an optical air eliminator input:

- Voltage – 10 to 28 VDC
- Current – 0.5 Amp maximum

Digital Inputs 1, 2, 3, 4, 5, and 6

- Active Low, normally pulled high
- Voltage: 5 to 28 VDC
- Current: 3 mA maximum sink current
- Maximum Frequency: 10 kHz

Outputs

The Register is equipped with six digital outputs and four solenoid outputs. These outputs allow the Register to communicate with meter system accessories such as solenoid- controlled valves, optical air and vapor eliminators, remote displays, printers, and third-party devices.

Digital Outputs 1, 2, 3, 4, 5, and 6

- Open drain output, active low to ground, thermally protected
- Voltage: 5 to 28 VDC
- Current: 500 mA maximum

Outputs for solenoids 1, 2, 3, and 4

- Open drain output, active low to ground, thermally protected
- Voltage: 12 VDC nominal
- Current: 1 A maximum
- Voltage: 24 VDC nominal
- Current: 0.5 A maximum

Pulse Output

- Voltage peak to peak – 5 to 28 V
- Frequency maximum – 7500 Hz

Scale Pulse Output

- Current sinking capability: 150 mA

Electrical Protection

- 5 A fuse on power cable

Communications

- RS-232
- RS-485
- CAN BUS – Consult the applicable Chassis Builder’s Guide, available from the truck chassis manufacturer.
- Ethernet (Gigabit)
- Bluetooth (wireless)
- Wi-Fi (wireless)

Printer (Epson Model 295)

- Voltage – 24 VDC
- Current – 0.8 Amp maximum
- Operating Temperature – -22 to 104 °F (-30 to 40 °C)

Regulatory & Certifications

The equipment is Listed by UL to applicable US and Canadian standards for use in hazardous locations under Liquid Controls file E180172.

LCR.iQ Serial Number tags

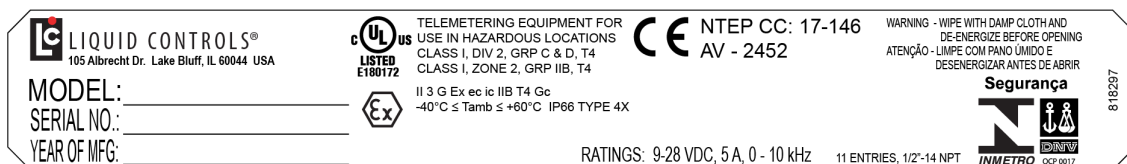
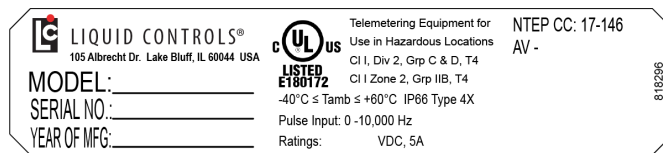

 **LIQUID CONTROLS®**
 105 Albrecht Drive, Lake Bluff, IL 60044 USA

BRAND: **Avery-Hardoll®**
MODEL: **MASTERLOAD.iQ™**
SERIAL NUMBER: XXXXXXXXX
YEAR OF MFG.: 2019
INPUT: 0-10 kHz, 9-28 VDC, 5A

 **E180172**

**TELEMETERING EQUIPMENT
 FOR USE IN HAZARDOUS LOCATIONS:**
 C1 I, Div. 2, Grp C & D, T4
 C1 I, Zone 2, Grp IIB, T4
 -40C < Tamb < +60 C IP66 Type 4X
 NTEP CC: 17-146

Class I

- Potentially Explosive Gas/Vapor Atmospheres.

Division 2 and Zone II

- Gases and vapor are not normally present in an explosive concentration but may accidentally exist during abnormal operations.



(Explosive Atmospheres symbol)

- This equipment has been found to comply with the European Directive for Equipment For Potentially Explosive Atmospheres 2014/34/EU (ATEX), Certification Scheme for Explosive Atmospheres of INTERNATIONAL ELECTROTECHNICAL COMMISSION (IECEX) and

Brazil's Portaria 179, subject to the following condition of safe use: Wipe with damp cloth and de-energize before opening. Certificates (if applicable) are issued by DNV GL and are etched on the tag.

II

- Suitable for use in surface installations.

3G

- Equipment for explosive gas atmospheres, having a “high” level of protection, which is not a source of ignition in normal operation or during expected malfunctions.

Ex ec ic

- Explosion protection is provided by the increased safety method of protection with the “ec” level of protection.

GC

- Equipment Protection Level level, per IEC 60079-0, EN 60079-0, and ABNT NBR IEC 60079-0. Suitable for installations in Zone 2.

Grp C&D and Grp IIB

- Flammable/explosive Gas groups.

T4

- Temperature class for surface temperature limitations. T4 means that at the point at the rated maximum ambient temperature, the equipment will not generate temperature higher than 135 °C.

-40 °C ≤ Tamb ≤ 60 °C

- Safe limits of ambient temperature.

IP66

- Ingress protection: dust-tight and protected against powerful water jetting.

Type 4X

- The enclosure has been evaluated by UL for outdoor use to provide protection against water and dust and an increased level of protection against corrosion; and that will be undamaged by the external formation of ice.



- Indicates conformity with all applicable Directives for products sold within the European Economic Area.

Specifications

LCR.iQ [®] Specifications			
Enclosure			
Waterproof, corrosion resistant and dust-proof - meets IP66 and UL Type 4X requirements			
Display			
7 inch, 800 x 480 high-resolution, Full Color			
Temperature Range		Input Voltage	
-40°F (-40°C) to 140°F (60°C)		9-28 VDC	
Keypad			
LED Back-lit		Petroleum-resistant	
Non-conductive, UV resistant elastomer		Field Replaceable	
Communication		I/O	
RS232/485 Comm Ports	2	Solenoid Outputs (high current)	4
RS485 Dedicated Comm Ports	2	Programmable Digital Outputs	6
WiFi	Internal antenna	Digital Inputs	6
Bluetooth	Internal antenna	RTD Probe Input	1
Extended range antenna (externally mounted)	Optional accessory	Optical Sensor Input	1
4-20 mA inputs	1 expandable to 7	Scalable Pulse Output (Additive inj, display, PLC)	1
Processor & Storage			
Dual-Core Processor Speed		800 MHz	
Internal RAM		1GB	
Internal Storage		128MB Flash NAND 8GB eMMC Flash drive	
External Storage via Removable USB			

Check for a Good Ground

After installing the ground kits, use a multimeter to confirm that the seat and printer are both grounded properly.

Follow these steps to verify a good ground connection:

1. Turn OFF all accessories, including the dome light, to prevent other currents from distorting the reading.
2. Take a multimeter and measure the resistance between the brackets the two ground strap bolts are fastened to. Find a clean spot on the brackets without paint to use as contact points. Other bolts on the brackets are often suitable.

Turn off accessories

If the multimeter reads “MΩ” or “KΩ”, typically, one of the accessories is still on.

- If the resistance is less than 3Ω , the system is grounded adequately.
- If the resistance is still greater than 3Ω , check for proper metal to metal contact on both ends of the ground strap. Clean any paint, dirt, or oxidation that may block the grounding point. If the resistance remains above 3Ω , attach the ground strap to a different ground point. Repeat the process until the ground resistance is below 3Ω .

Verify good contact

If operator receives a ESD discharge when leaving the seat, the ground strap is not installed correctly.

FCC Compliance



Unique Identifier: MASTERLOADx.iQ

Responsible Party:

Liquid Controls LLC

105 Albrecht Drive

Lake Bluff, IL 60044 USA

www.LCmeter.com

FCC Compliance Statement: This device complies with Part 15 of the FCC Rules. Operation is subject to the following two conditions: (1) This device may not cause harmful interference, and (2) this device must accept any interference received, including interference that may cause undesired operation.

This device contains FCC ID Z64-WL18DBMOD, IC: 4511-WL18DBMOD, and may optionally contain FCC ID MCQ-XBPS3B, IC: 1846A-XBPS3B (DIGI Module).

This equipment has been tested and found to comply with the limits for a Class B digital device, pursuant to part 15 of the FCC Rules. These limits are designed to provide reasonable protection against harmful interference in a residential installation. This equipment generates, uses, and can radiate radio frequency energy and, if not installed and used in accordance with the instructions, may cause harmful interference to radio communications. However, there is no guarantee that interference will not occur in a particular installation. If this equipment does cause harmful interference to radio or television reception, which can be determined by turning the equipment off and on, the user is encouraged to try to correct the interference by one or more of the following measures:

- Reorient or relocate the receiving antenna.
- Increase the separation between the equipment and receiver.
- Connect the equipment into an outlet on a circuit different from that to which the receiver is connected.
- Consult the dealer or an experienced radio/TV technician for help.

Any changes or modifications to this equipment, not expressly approved by Liquid Controls could void the user's authority to operate the equipment.

This device complies with the ISED Canada license-exempt RSS standard(s). Operation is subject to the following two conditions: (1) This device may not cause harmful interference, and (2) this device must accept any interference received, including interference that may cause undesired operation.

Cet appareil est conforme à la norme RSS exempte de licence d'ISED Canada. L'opération est sous réserve des deux conditions suivantes: (1) Cet appareil ne doit pas causer d'interférences; et (2) Cet appareil doit accepter toute interference fonctionnement indésirable de l'appareil CAN ICES-3(B)/NMB-3(B)

This device could automatically discontinue transmission in case of absence of information to transmit or operational failure. Note that this is not intended to prohibit transmission of control or signaling information or the use of repetitive codes where required by the technology.

The device for operation in the band 5150-5250 MHz is only for indoor use to reduce the potential for harmful interference to co-channel mobile satellite systems.

High power radars are allocated primary users (i.e. priority users) of the bands 5250-5350MHz and 5650-5850MHz and that these radars could cause interference and or damage to the Wi-Fi transceiver.

This equipment complies with the FCC/IC radiation exposure limits set forth for an uncontrolled environment.

Only antennas specified by Liquid Controls shall be used with this equipment. The antenna for this equipment shall be installed and operated to maintain a separation distance of 20 cm or greater between the antenna and any person.

The antenna for this equipment shall not be co-located with or operated in conjunction with any other antenna or transmitter. The antennas shall be installed and operated to maintain a separation distance of 20 cm or greater between any other radiating antenna.

The FCC ID and IC can also be viewed on the Register by pressing <Main Menu> then <Diagnostics> then <About>.

Dimensions - Panel Mount

FRONT VIEW

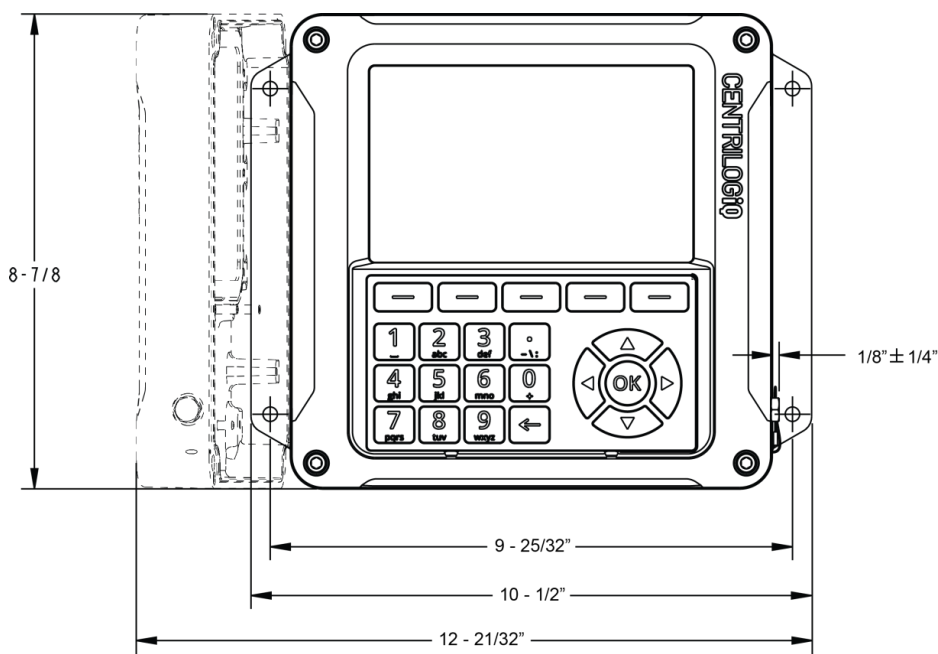

BACK VIEW

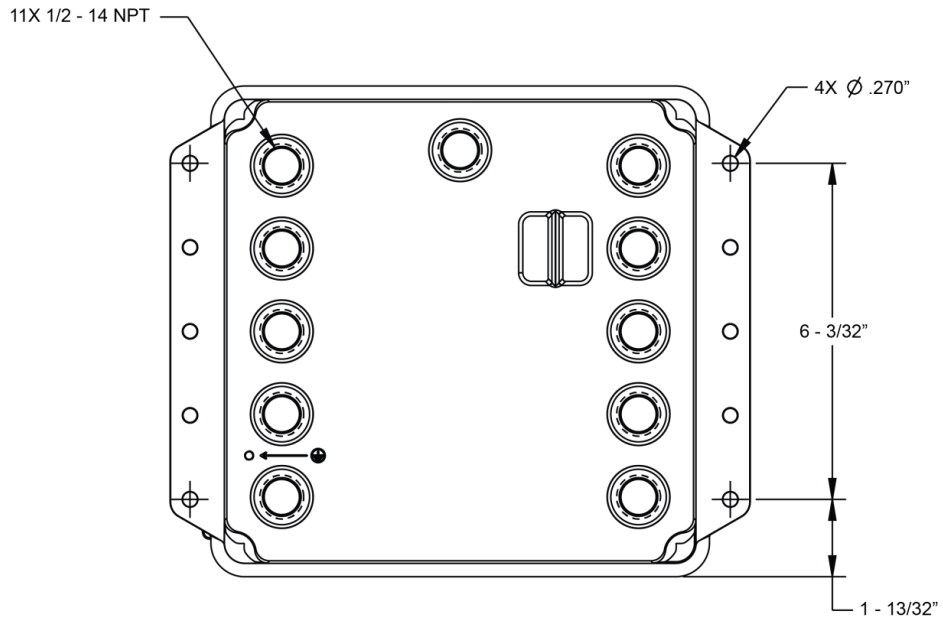

SIDE VIEW

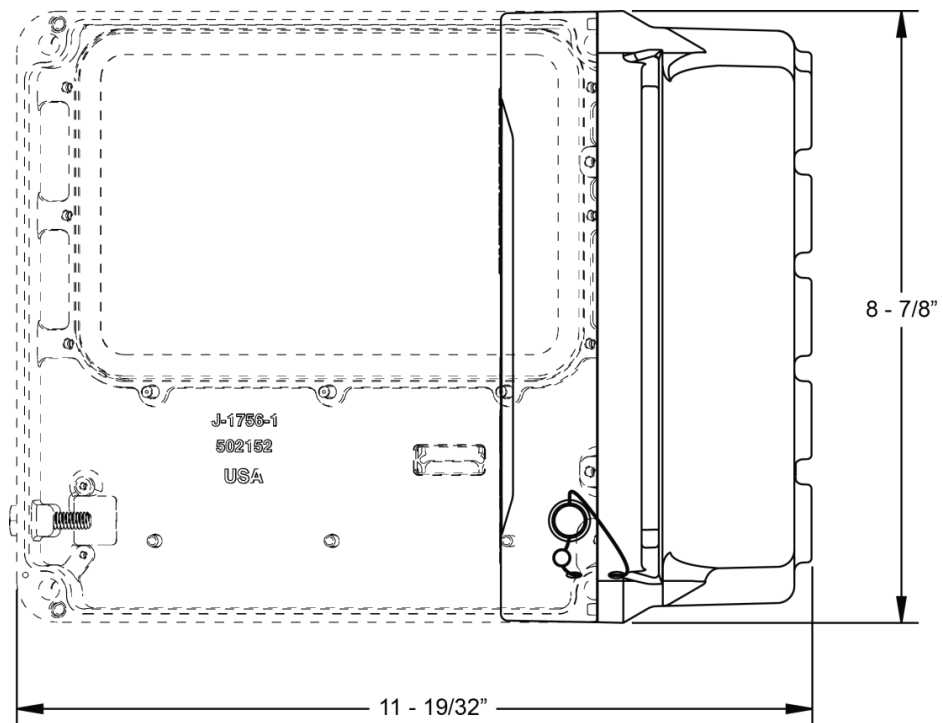

TOP VIEW

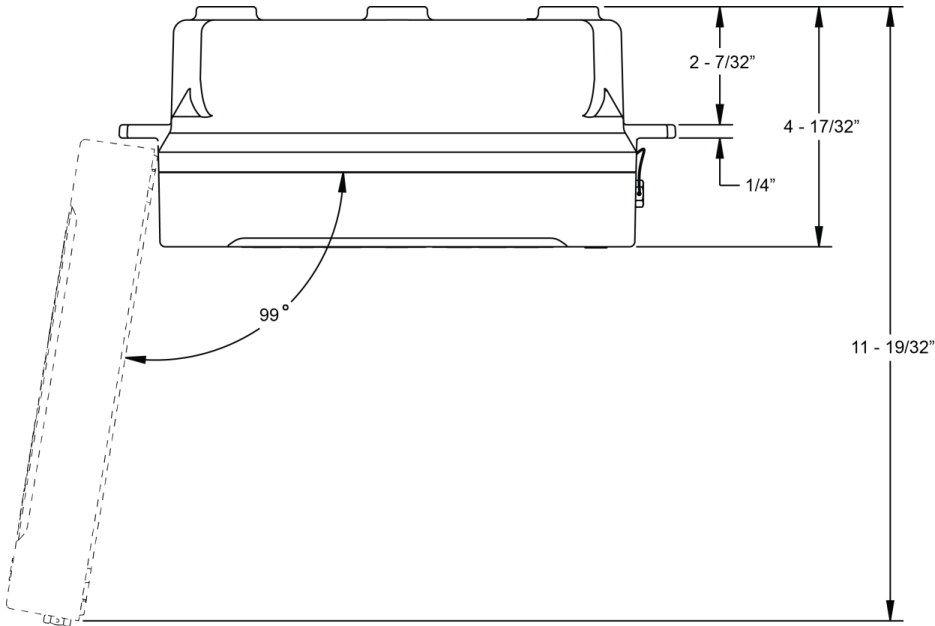

Dimensions - Meter Mount

Front View

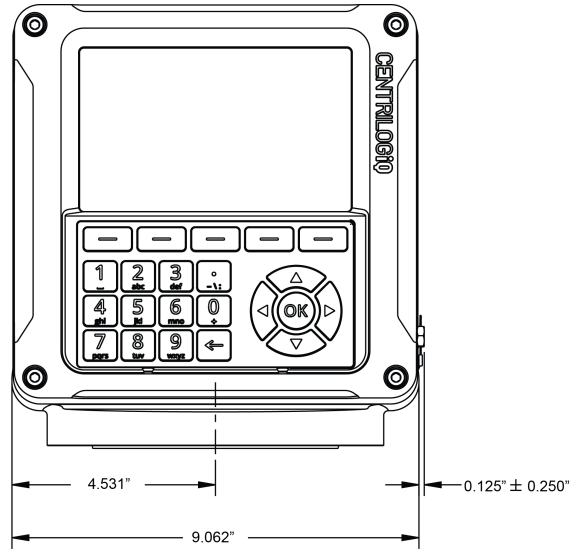

Back View

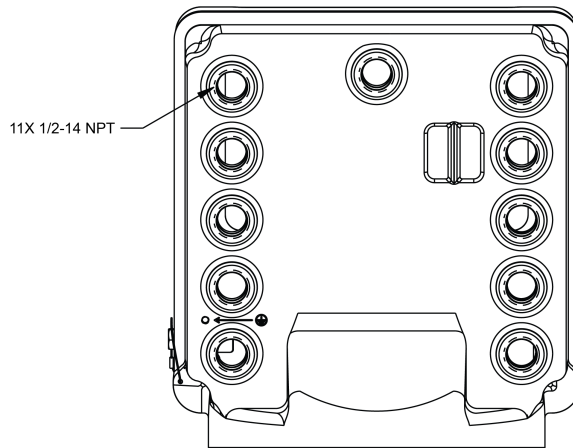

Side view

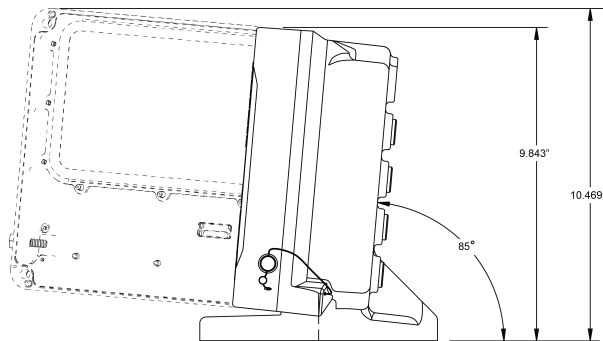

Top View

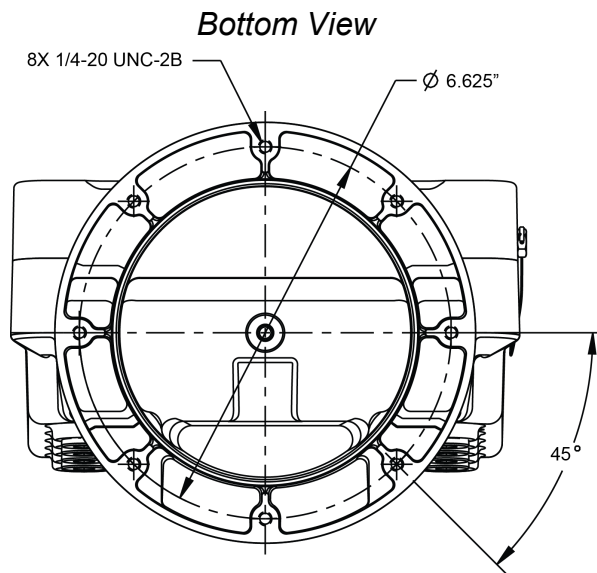
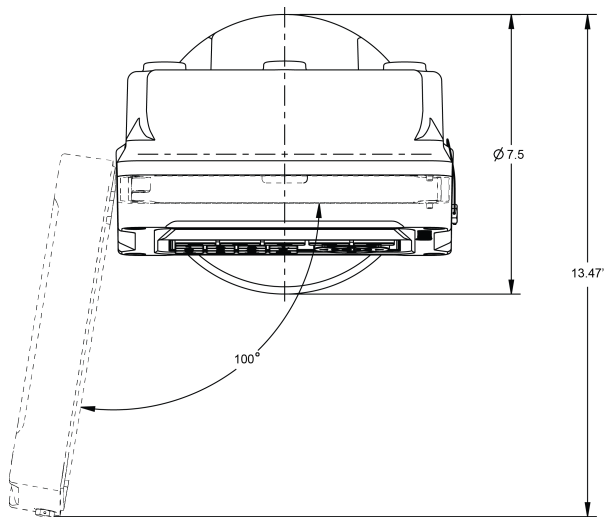

Setup and Operation

The Liquid Controls LCR.iQ is a microprocessor-based electronic meter register that can be used for Weights & Measures approved custody transfer actions in mobile or fixed installations.

NOTE: Throughout this manual, the LCR.iQ is referred to as “Register” (unless otherwise specifically referenced by name).

The Register is a self-contained unit. All operation, setup, and configuration functions can be carried out using the Register function keys and alphanumeric keypad. No lap pads, laptops, or other data entry devices are required.

A complete Liquid Controls meter system not only accurately measures product, it also regulates product flow and removes contaminants in order to produce the optimal conditions for measurement. Typical systems include an air/vapor eliminator, strainer, meter, register, and control valve.

It's just that simple.

Liquid Controls engineers took an aggressive approach by designing the Register from the operator's perspective, as if little training should be required to use it. The result is a user-guided, configurable interface that walks the operator through the fueling operation, minimizing chance for error.

COMMON FUELING PROCESSES COMPLETED IN 3 STEPS OR LESS

User-configurable fueling processes control the number of steps required for the operator to complete his or her delivery. Pump and print operations are complete in two steps, using one function key!



OPERATOR FRIENDLY SCREENS WITH DAY / NIGHT MODES AND BRIGHTNESS CONTROL

The Register screens adapt to the operator. Idle screen shows the last delivery data, changing to full screen, active fueling mode with yellow background when **Start** is pressed. Operators have the option to see fueling details during active fueling and can easily adjust screen brightness and toggle between day or night modes for reduced eye strain.



SIMPLE METER CALIBRATION

The intuitive calibration of the Register enables you to simply enter the "corrected prover" or master meter volume, and it will do the rest. With up to 16 points of linearization, the Register is by far the most precise register ever made.



REAL-TIME ON-SCREEN DIAGNOSTICS

The Register provides the operator with real-time diagnostics. It also provides an error indicator and message for any error condition that arises. Also, the operator can easily print the report for corrective action and reference.



SECURITY

The Register has been designed with the highest levels of security according to Center for Internet Security (CIS) benchmarks. As an Internet-enabled device, it is imperative that any weights-and-measures-approved devices meet or exceed CIS benchmarks for security. This level of stringency also provides a robust user level security to prevent tampering or inadvertent access to forbidden areas and settings on the device. Safety and security go hand-in-hand, and these are the number one priority at Liquid Controls.



CONFIGURABLE DELIVERY SETUP

Guide the operator through the fueling process of your choosing. From basic pump-and-print to presetting—either by volume or product weight. It's easy to adjust price per gallon, percent tax, or select multiple deliveries on a single ticket.



CONFIGURABLE IDLE SCREEN

Easily configure the idle screen fields the operator sees before, during, and after fueling. All units of measure including date and time formats are also configurable to comply with local standards.



Software License Agreement

Read this license carefully. You agree that by using the itemized software package, you have agreed to the software license terms and conditions. This agreement constitutes complete and entire agreement between you and Liquid Controls with respect to this product.

1. Liquid Controls hereby grants to Licensee a non exclusive license to use SR1000 and SR1010 (hereinafter referred to as "Licensed Software").
2. Under the License granted herein, Licensee may use the itemized machine readable (executable code) copy of the Software, including any subsequent updates which maybe provided. Licensee shall not, without Liquid Controls prior written consent, (a) rent, lease, lend, sublease or otherwise transfer the materials hereunder; (b) remove or obscure proprietary or copyright notices which may be set forth on the Licensed Software; or (c) alter, decompile, or disassemble the program.
3. One (1) copy of the Licensed Software, including any software distributed on disks may be made for backup purposes only. No other copies may be made or used without the written consent of Liquid Controls.
4. Title. No title to ownership of any Licensed Software is transferred to the Licensee.
5. Upgrades. License upgrades may become available for the Licensed Software. Any cost associated with such upgrades will solely be determined by Liquid Controls.
6. Warranty. Liquid Controls makes and licensee receives no warranty, express or implied, and thereby expressly excludes all warranties of merchantability and fitness for a particular purpose.
7. Limitation of Liability. Licensee shall have the sole responsibility for adequate protection and backup of its data in connection with the Licensed Software. In no event shall Liquid Controls be liable for (a) special, indirect or consequential damages; (b) any damages whatsoever resulting from loss of use, data, or profits, product, inaccurate input or work delays, or any direct property damage arising out of or in connection with this agreement or the use or performance of the Licensed Software.
8. Termination. Liquid Controls may terminate this software license granted hereunder and require return of the Licensed Software if Licensee fails to comply with these license terms and conditions.
9. Licensee acknowledges that it has read this agreement, understands it, and agrees to be bound by its terms, and further agrees that this is the complete and exclusive statement of the agreement between Liquid Controls and Licensee, which supersedes and merges all prior proposals, understandings, and all other agreements, oral or written, between the parties relating to this agreement. This agreement may not be modified or altered except by written instrument duly executed by both parties.
10. This Agreement and performance hereunder shall be construed and interpreted under the laws of the State of Illinois.

11. If any provision of this agreement is invalid under any applicable statute or rule of law, it is to that extent to be deemed omitted.
12. Licensee may not assign or sublicense, without the prior written consent of Liquid Controls, its rights, duties, or obligations under this Agreement to any person or entity in whole or in part.
13. The waiver or failure of Liquid Controls to exercise in any respect any right provided herein shall not be deemed a waiver of any further right hereunder.

Operational Information & Main Menu

This figure provides a visual overview of the register. In the sections below, you can find general information on the operation of the register, screen layout, types of display screens, and the keypad.



Delivery Screen Layouts

Delivery Screens

The user interacts with the register through the delivery screens. A user can view delivery details, and also enter information before, during, and after completing a transaction. There are three separate delivery screens that may appear:

- Idle / Home Delivery Screen
- Active Delivery Screen
- Active Delivery Screen - Show Details

Idle / Home Delivery Screen

The idle delivery screen will appear when the Register is between deliveries—and not in any of the setup screens. This is also known as the **Home** screen, since a typical user will spend much time interacting with the Register here.

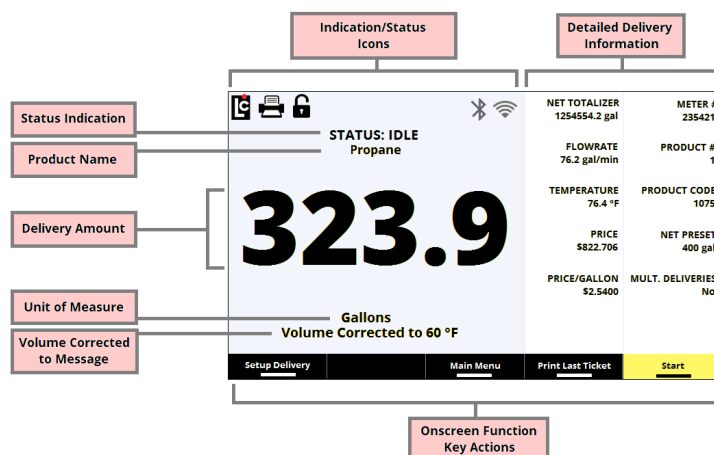

Active Delivery Screen (Full Screen)

The Active delivery screen appears any time the Register is performing an active delivery. The default active delivery screen is the Full Screen mode—which displays large, bright delivery volume, along with the base regulatory details for a transaction.

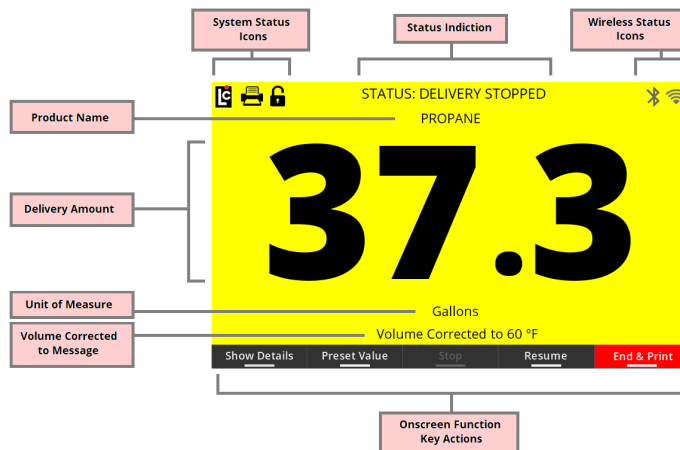

Active Delivery Screen - Show Details

Display this screen at any time during a delivery by pressing the function key that corresponds to **Show Details**. The **Show Details** screen will display up to two columns of additional information about the active delivery. These columns are configurable when setting up the Register, and can display up to 12 separate parameters of data during an active delivery.

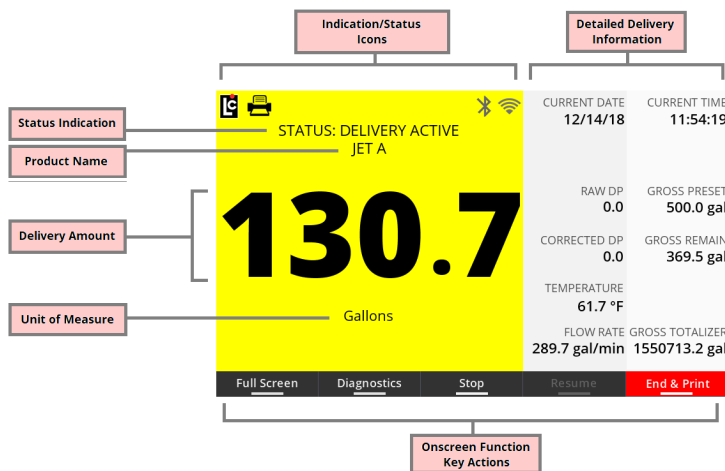

Display Screen Types

With menus, you can quickly navigate to various operational screens available within the Register. There are two menus accessible to the user, the **Main Menu** and the **Setup Menu**. Access to the main menu is accessible from the idle delivery screens, or anytime the Register first enters the calibration mode (in a non-active delivery mode). Access to the setup menu is

available from the **Main Menu** only. Each menu provides access to a number of operational screens.

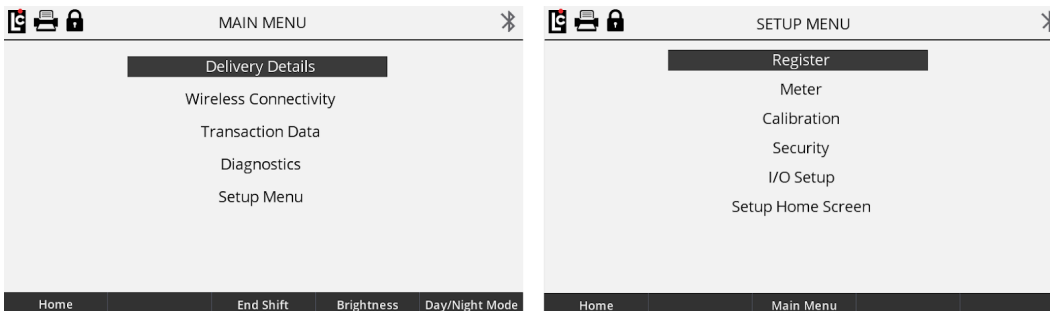

Detailed Operational Screens appear anytime a selection is made to one of the menu items. When inside a detailed operational screen, you will see the title of the screen, the page number (if multiple pages are available), as well as all available parameter fields on that page.

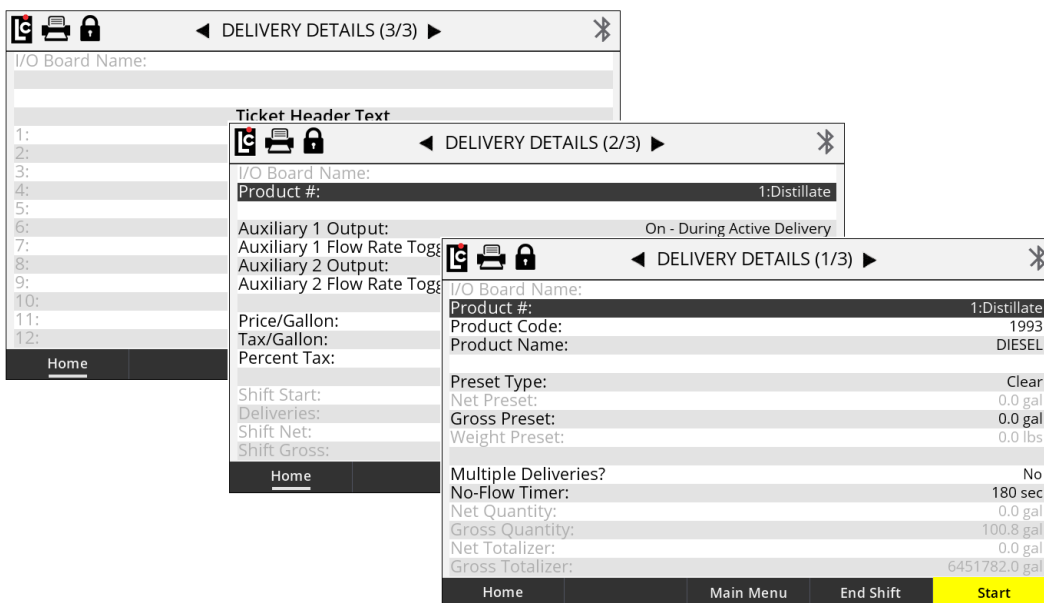

Parameter fields display current information that has already been setup. Other general information may also be shown. There are three main types of parameter fields within an operation screen: list boxes, text fields, and read-only fields.



List Box parameter fields, when selected, provide the user with a list of options that are available for that specific parameter. A list may be a drop-down list of available settings, or as simple **Yes/No** selection. When the user selects a list box parameter, the list box will display on the screen and the user can use the navigation keys to scroll up or down through the available list of options. Press **OK** to make a selection.

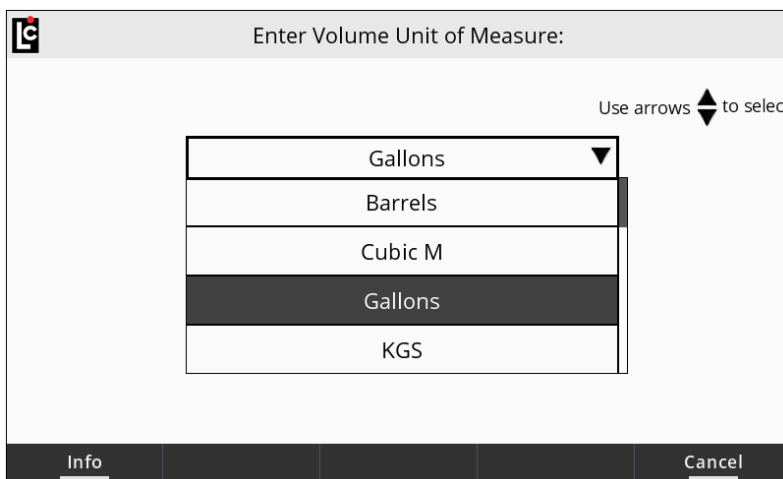

Text box: When a text box parameter field has been selected, the user can manually enter text information specific to that parameter. Text for these fields can be entered using the alphanumeric keypad. Keep in mind that a text field can either be **numeric** (only numbers are permitted for that parameter) or **alphanumeric** (either numbers or letters are permitted for that specific parameter).

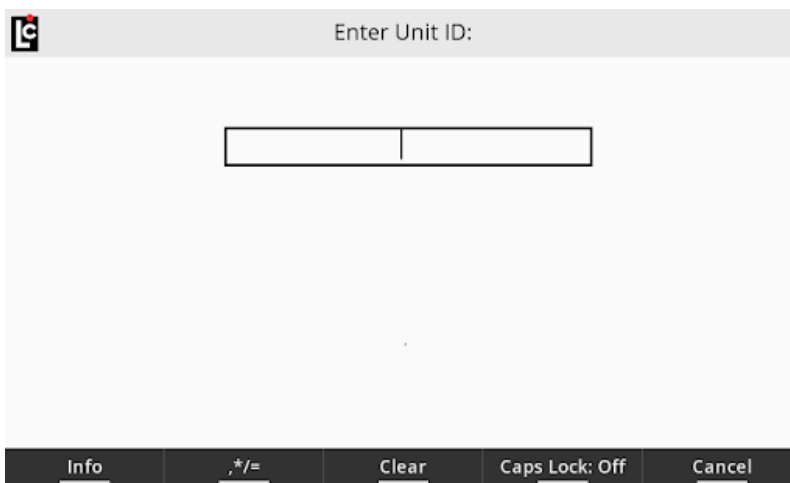

Read-only fields are for informational purposes, and display an Register parameter field that maybe be useful when setting up or programming the register. Read-only fields always appear on the screen in a gray text color.

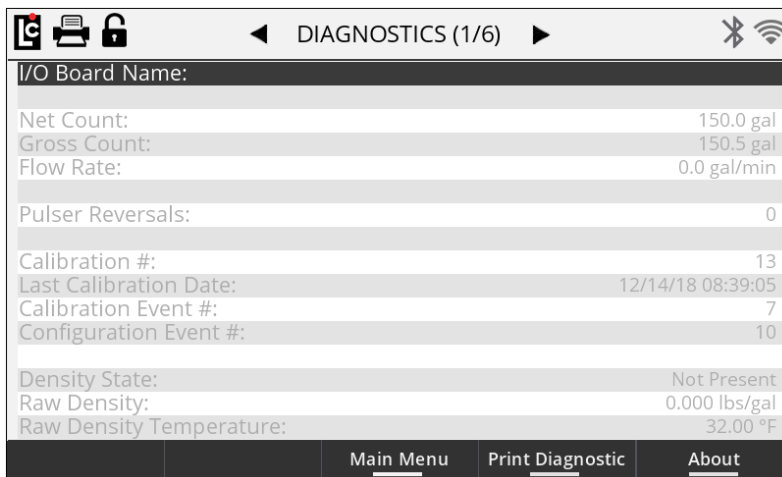

Keypad Interface

Keypad

The Register keypad serves as a tool for basic delivery functionality, data entry and screen navigation. There are three sections of the keypad, including function keys, alphanumeric keys and, navigation keys. See the detail explanations below.



Function keys provide a simple way to perform specific tasks such as starting a delivery, setting a preset amount, or accessing a different menu. Each function key corresponds to an onscreen action. The onscreen action of the function keys will vary on different screens or menus.

Onscreen actions that appear in white are actions that are available to the user. Onscreen actions that appear in gray are unavailable (in the current context). Onscreen actions that correspond to a function key may have different background color for easier identification and operation. In some screens, one or more of the function keys may not correspond to any onscreen action. In such cases, the onscreen section for that function key will be empty.



Navigation Keys give the user a simple way to move among screens, and also help in making selections. The up and down arrow keys move the selection bar up and down through screens, menus, and list boxes. The right and left arrow keys are for scrolling through setup screens, and also move a cursor left or right within a text box. Use the **OK** key to enter a field that you've selected, or to accept data that has been selected or entered for a field.

Start	Start will reset the LCR.iQ for a new delivery
End & Print	End & Print will complete the current delivery and print a ticket
Stop	Stop will pause an active delivery and allow access to addition delivery parameters
Resume	Resume will continue a delivery that has been paused by pressing the Stop key
Show Details	Show Details will change the delivery screen from full screen to details screen mode
Full Screen	Full Screen will change the delivery screen from details screen to full screen mode
Preset Volume	Preset Volume will display a numeric text prompt to enter a preset amount for delivery
Diagnostics	Diagnostics will take the user into the diagnostics screens
Home	Home will return the LCR.iQ back to the idle delivery screen (Home)
About	About will display information about the LCR.iQ such as software versions and regulations
View Message Log	View Message Log will show details of the selected message log data type
Close	Close will close the current viewable screen
Hose Reset	Hose reset will actuate the hose reset feature if activated
Print Last Ticket	Print Last Ticket will reprint a copy of the previous delivery ticket
Print Diagnostic	Print Diagnostic will print a copy of the current diagnostic information
Print	Print will print off a transaction record, audit log or data log depending on the screen selected
Setup Delivery	Setup Delivery will allow access to the setup delivery prompts from the idle delivery screen
< Back	<Back will navigate to a previous option in a setup screen
Next>	Next> will navigate to the next option in a setup screen
Info	Info will display information about the current display screen and its selection options
Close Info	Close Info will close the info screen and return to the current display screen
End Shift	End Shift will end the current active shift and print the active shift ticket
Brightness	Brightness will display a selection bar for setting the brightness of the display
Day/Night Mode	Day/Night Mode will toggle between the day mode and night mode of the display
Advanced Setup	Advanced Setup will allow access from delivery setup menu to delivery details screens
Main Menu	Main Menu will navigate to the main menu screen
Setup Menu	Setup Menu will navigate to the setup menu screen
Clear	Clear will clear all of the current text in a text box leaving just a blank cursor
Caps Lock:Off	Caps Lock: Off will toggle the Caps lock to On
Caps Lock:On	Caps Lock: On will toggle the Caps lock to Off
Cancel	Cancel will cancel an entry and return to the previous screen and not save changes
Services	Services will access the services screens in the I/O setup menu
Audit Trail	Audit Trail will access the audit trail screen from the security menu
Software Update	Software Update will access the software update screen from the security menu
<*/=	<*/= will allow access to addition text characters that can be used in text fields
Run Calibration	Run Calibration starts the calibration process and resets the LCR.iQ to 0
End	End will terminate a calibration and return the screen back to the current calibration screen

Alphanumeric Keys are primarily for data entry, such as setting a preset amount, entering a delivery prompt, or programming the register. Each alpha-numeric key has the ability to display multiple characters according to the number of times that you press a key. Press an alpha-numeric key once to display the primary key function, which is the largest character shown on each key. Here's an example: If the cursor is within a text box field, pressing the **5** key one time will display the number 5.



Pressing an alpha-numeric key multiple times will display additional characters. These additional characters are the smaller characters shown on each key. (Default setting is Caps Lock set to Off, which results in lower case letters. Press the Caps Lock key to turn on capitalization and enter all capital letters.) Let's extend the example above: With the cursor in a text box field, pressing the **5** key twice (within 1 second) will display the letter J. Pressing the **5** key three times successively (within 1 second) will display a K; pressing the key four times will display an L.

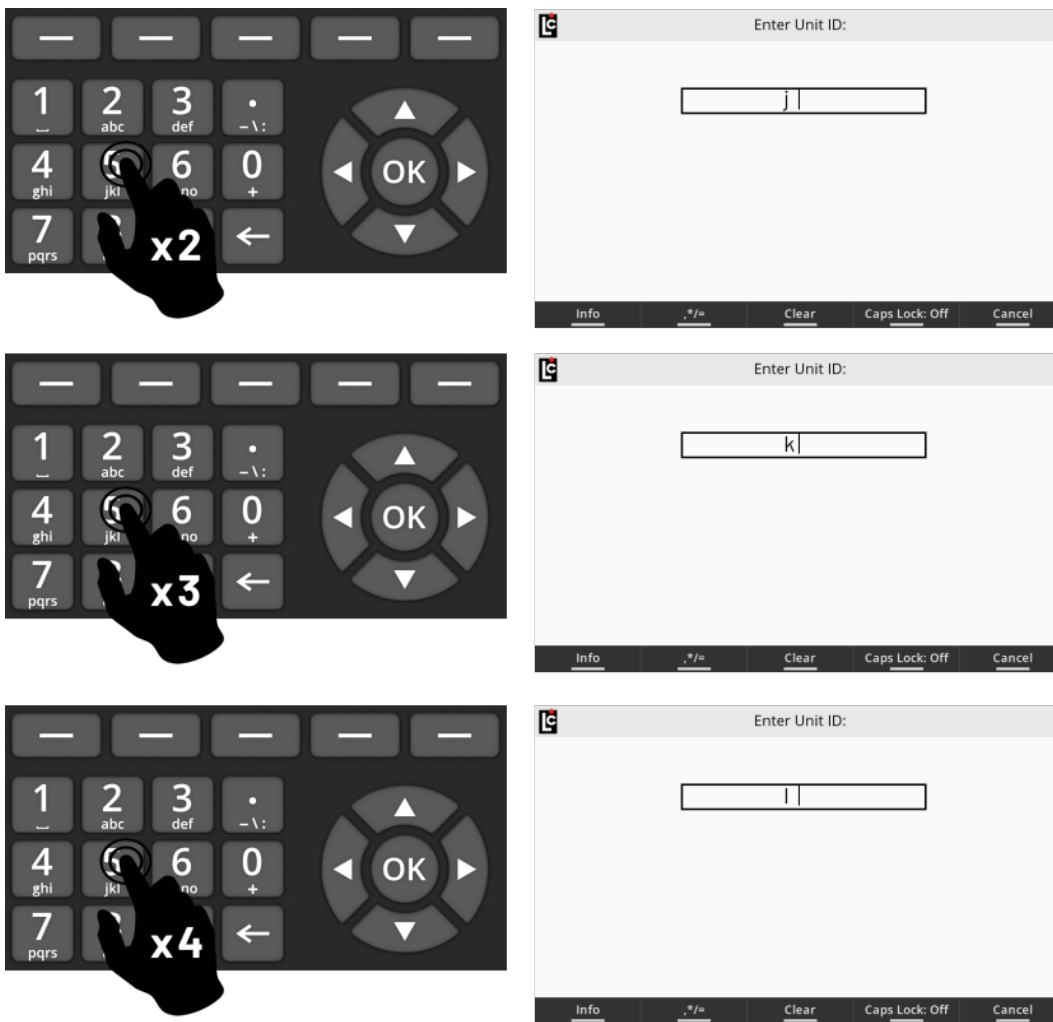

When accessing a numeric-only text box field, the alphanumeric keys will only display numbers when pressed. Pressing a key multiple times within a numeric-only field will simply display the same number (repeatedly).

There is an additional alpha-numeric key that enables quick access to the most commonly used symbols on the Register. These options are . (point) - (dash) \ (slash) : (colon) .

The location for this key can be seen in the figure below.



NOTE: Additional symbols are available when a text box screen is displayed. A function key containing the symbols , * / = will appear. Pressing this key will display a chart of many additional available symbols. Use the navigation keys to select these symbols.

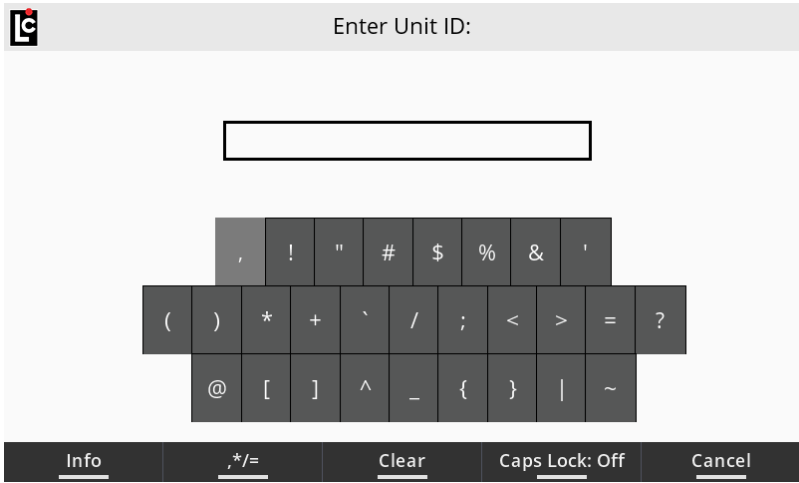

Delivery Details

This section contains additional delivery parameters that you can configure for display on the [Delivery Screens](#)²⁹. There are three screens that contains a number of parameters each. See the explanations for each below.

Delivery Details (1/4)

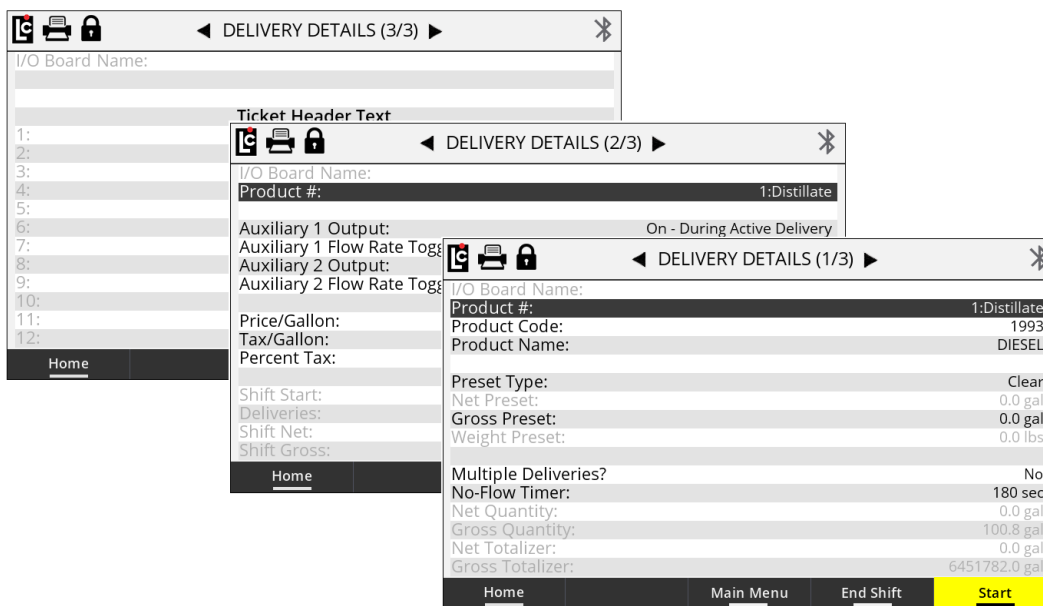

I/O Board Name

(This appears on each of the three screens)

A text field that is used to identify the currently selected I/O board in the I/O board # field. The name will display on some other screens where it is necessary to clearly identify the selected board. **(Maximum - 16 Characters)**

Product

(This appears on each of the three screens)

A listing of the 16 products available for setting up and calibrating the Register.

Options: Products 1-16 are available for setup. Only setup and calibrate products that are to be used by the Register.

Product Code

A text field for identifying the selected product with a code. The product code will appear on most ticket formats to identify the product that was delivered. **(Maximum - 5 Alphanumeric characters)**

Product Name

A text field for identifying the selected product with a specific name. This name will appear on most ticket formats.

Preset Type

A list box for specifying how the Register will react when it reaches the preset amount. The choice here also affects when the end delivery command is sent and when the ticket will print.

Options:

- **Clear** – At the point when the Register reaches the preset value, the delivery ends automatically, the ticket is printed, and the preset value is set to 0.
- **Multiple** – At the point when the Register reaches the preset value, the delivery is paused but remains active until the user either (a) presses **Resume**, (b) sets a new preset and presses **Resume**, or (c) ends the delivery by pressing the **End & Print** button and the preset value is set to 0.
- **Retain** – At the point when the Register reaches the preset value, the delivery automatically ends, the ticket prints, and the original preset value is retained for the next delivery.

Net Preset

A numeric text field for the net preset value—if net presets are accepted and temperature compensation is active. **(Maximum - 7 numeric characters)**

Gross Preset

A numeric text field for the gross preset value—if gross presets are accepted. **(Maximum - 7 numeric characters)**

Weight Preset

A numeric text field for the weight preset value—if weight presets are accepted. **(Maximum - 7 numeric characters)**

Price Preset

A numeric text field for the price preset value—if price presets are accepted. (**Maximum - 7 numeric characters**)

Multiple Deliveries?

A list box in which you can specify if the **Multiple Deliveries** feature is to be on or off. If **Multiple Deliveries** is set to **Yes**, you can fill multiple tanks at one location without being affected by the **No Flow Timer** feature (see below. This only applies to the next delivery, and will revert back to **No** automatically when the delivery completes.

If this field is set to **No**, any deliveries will need to be within the value specified in **No Flow Timer**.

NOTE: There is also a printer parameter, **Print Multiple Deliveries Per Site Message in Register 3/3**, that is directly affected by this setting.

No Flow Timer

A numeric-only field for specifying the duration of the **No Flow Timer**. This is an internal timer that begins when the Register senses that there is no longer any product moving through the meter. If this timer counts up to its set point, the Register will assume that the delivery is complete and a ticker will print automatically. The default value for this field is **180 (seconds)**. Deactivate this feature by entering 0 seconds, which permits filling multiple tanks at a single location simultaneously. The timer helps to ensure that deliveries are not split between authorized and unauthorized locations. If the value is set to 0—or any value greater than 180—and the **Print Multiple Deliveries Per Site** message is set to **On**, the **Multiple Deliveries At One Site** message will print on the delivery ticket. (**Maximum - 3600 Seconds**)

Price/Unit

A numeric-only text field for specifying a price per-unit. (**Maximum - 7 numeric characters**)

NOTE: The unit label will vary depending on the unit of measure that has been set up in the Register.

Tax/Unit

A numeric-only text field that is used to enter a per unit tax to be applied to the volume delivered. **(Maximum - 7 numeric characters)**

NOTE: The unit label will vary depending on the unit of measure that has been set up in the Register.

Percent Tax

A numeric-only text field for specifying a percent/unit tax that applies to the Price/Unit **(Maximum - 6 numeric characters)**

Delivery Details (2/4)

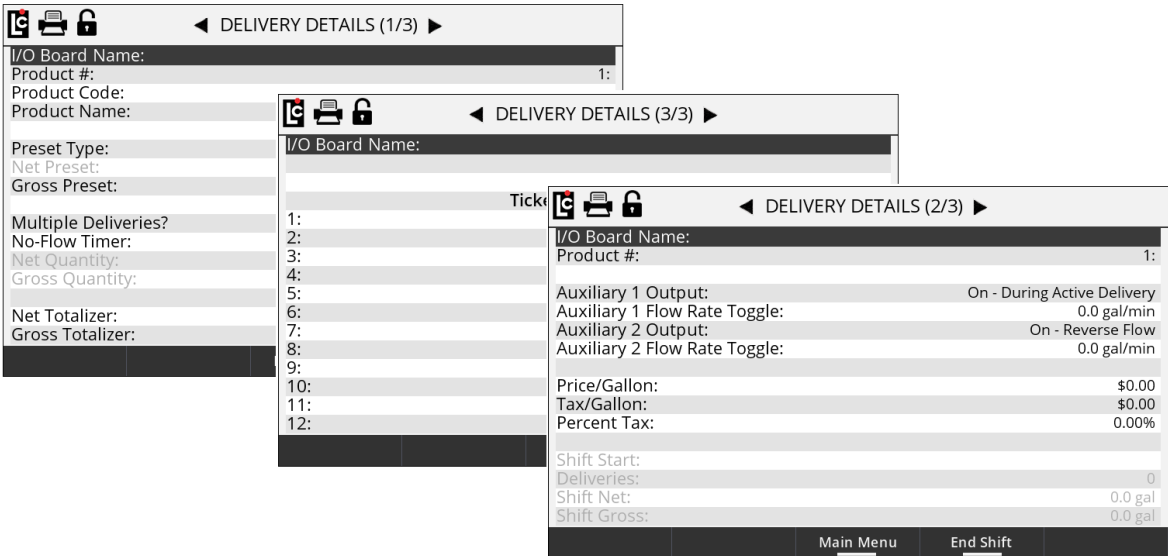

Auxiliary 1 Output

A list box that determines how any digital output that is set to AUX 1 will operate on the selected product. To control external components, there are several features in the Register that can be set to perform according to the Auxiliary 1 and Auxiliary 2 settings. This includes pumps, injectors, PTO, throttle, alarms, and reset pulse, among others.

Options:

- **Off** – Any output set to AUX 1 Calibration Mode Settings will always be off (inactive).
- **On** – Any output set to AUX 1 Calibration Mode Settings will always be on (Active and Sinking to ground).
- **On - During Active Delivery** – Any output set to AUX 1 Calibration Mode Settings will turn on (Sink to ground) when a delivery is started. It will turn off when the delivery is complete.
- **On - During Run State** – Any output set to AUX 1 Calibration Mode Settings will turn on (Sink to ground) when a delivery is active and not paused. The output will be on when a delivery begins. However, if the delivery pauses, the output will turn off until the delivery resumes. If the **End of delivery** command is given, the output will remain off and the delivery will end.
- **On - Flow Rate Monitor** – Any output set to AUX 1 Calibration Mode Settings will be on when a delivery is active. However, it will deactivate if the flow rate meets or exceeds 40 units/time. If the flow rate does not meet or exceed 40 units/time, the output will remain on.
- **On - Reverse Flow** – Any output set to AUX 1 Calibration Mode Settings will be off when a delivery begins. It will only turn on when the register detects flow in the negative or reverse direction.
- **Reset Pulse/Delivery Start** – For any delivery that uses 3rd-party remote counters requiring a reset pulse to 0.0, any output set to AUX 1 Calibration Mode Settings will output a short pulse at the start of a delivery.
- **Toggle Flow Rate** – Any output set to AUX 1 Calibration Mode Settings will turn on once the flow rate of the Register exceeds the set flow rate point in the **Auxiliary 1 Flow Rate Toggle** field. See below.
- **Calibrated Scaled Pulse Output** – Any output set to AUX 1 Calibration Mode Settings will be a calibrated pulse output that scales according to the **Pulse Output Frequency** setting in the calibration mode.

Auxiliary 1 Flow Rate Toggle

A numeric-text field that can be used to program a flow rate set point when the Aux 1 is set to **Toggle flow rate**. Auxiliary 1 remains activated above the set flow rate value and deactivates when the flow rate falls below the value.

A common use for this output is an air operated valve (AOV) on the pump. When the flow rate value is attained, the AOV is activated switching the pump from low-bypass pressure mode to full-flow fuel mode (high bypass pressure). When the flow rate falls below the set value, the AOV deactivates and the pump returns to low-flow.

Another possible output is the engine throttle—to increase and decrease the RPM of the pump shaft. In applications such as these, the flow rate value in this field should be below the low-flow rate with a fully open nozzle—or the output will never turn on.

Another application of this field is to set the value as a maximum flow rate at which a valve should be closed. On fuel delivery trucks, flow valves often activate an internal switch at approximately 18 GPM (68 LPM). The value of this field is unique to each product.

Auxiliary 2 Output

A listing that determines how any digital output that is set to AUX 2 will operate on the selected product. To control external components, there are several features in the Register that can be set to perform according to the Auxiliary 1 and Auxiliary 2 settings. This includes pumps, injectors, PTO, throttle, alarms, reset pulse, among others

Options:

- **Off** – Any output set to AUX 2 Calibration Mode Settings will always be off (inactive).
- **On** – Any output set to AUX 2 Calibration Mode Settings will always be on (Active and Sinking to ground).
- **On - During Active Delivery** – Any output set to AUX 1 Calibration Mode Settings will turn on (Sink to ground) when a delivery is started. It will turn off when the delivery is complete.
- **On - During Run State** – Any output set to AUX 1 Calibration Mode Settings will turn on (Sink to ground) when a delivery is active and not paused. The output will be on when a delivery begins. However, if the delivery pauses, the output will turn off until the delivery resumes. If the **End of delivery** command is given, the output will remain off and the delivery will end.

- **On - Flow Rate Monitor** – Any output set to AUX 2 Calibration Mode Settings will be on when a delivery is active. However, it will deactivate if the flow rate meets or exceeds 40 units/time. If the flow rate does not meet or exceed 40 units/time, the output will remain on.
- **On - Reverse Flow** – Any output set to AUX 2 Calibration Mode Settings will be off when a delivery begins. It will only turn on when the register detects flow in the negative or reverse direction.
- **Reset Pulse/Delivery Start** – For any delivery that uses 3rd-party remote counters requiring a reset pulse to 0.0, any output set to AUX 2 Calibration Mode Settings will output a short pulse at the start of a delivery.
- **Toggle Flow Rate** – Any output set to AUX 2 Calibration Mode Settings will turn on once the flow rate of the Register exceeds the set flow rate point in the **Auxiliary 1 Flow Rate Toggle** field. See below.
- **Calibrated Scaled Pulse Output** – Any output set to AUX 2 Calibration Mode Settings will be a calibrated pulse output that scales according to the **Pulse Output Frequency** setting in the calibration mode.

Auxiliary 2 Flow Rate Toggle

A numeric-text field that can be used to program a flow rate set point when the AUX 2 is set to **Toggle flow rate**. Auxiliary 2 remains activated above the set flow rate value and deactivates when the flow rate falls below the value.

Shift Start

A read-only field that displays the time and date that the current active shift began.

Deliveries

A read-only field that displays the number of deliveries made during the currently active shift. This value will reset each time the **Clear-Shift** command is given and the shift ticket prints.

Shift Net

A read-only field that will display the total net volume that was delivered during the currently active shift. This value will reset each time the **Clear-Shift** command is given and the shift ticket prints.

Shift Gross

A read-only field that will display the total gross volume that was delivered during the currently active shift. This value will reset each time the **Clear-Shift** command is given and the shift ticket prints.

Net Quantity

A read-only numeric field that displays the current net delivery quantity.

Gross Quantity

A read-only numeric field that displays the current gross delivery quantity.

Net Totalizer

A numeric-text field that display the current accumulative net totalizer value of the selected product. This is a non-resettable totalizer. However, it is programmable in the Weight and Measures (Calibration) mode—if reprogramming is necessary. **(Maximum - 9 numeric characters)**

Gross Totalizer

A numeric-text field that displays the current accumulative gross totalizer value of the selected product. This is a non-resettable totalizer. However, it is programmable in the Weight and Measures (Calibration) mode—if reprogramming is necessary. **(Maximum - 9 numeric characters)**

Delivery Details (3/4)

Ticket Header Text 1-12

Each ticket header line is an alphanumeric text field that is available for entering data that will print at the top of each ticket. Typically, this is useful for printing the company name, address, phone number, email, etc of the marketer. You can enter up to 12 lines of header text, and also insert blank lines between lines of text.

Header lines 11 and 12 are for Auxiliary 1 (Header 11) and Auxiliary 2 (Header 12). These are programmable only when the Register is in the calibration mode. Use these lines to print a specific message on the ticket when triggered by the either of these **Auxiliary** settings: **On**, **On During Delivery**, or **On During Run State**.

Delivery Details (4/4)

Ticket Footer Text 1-8

Each ticket footer line is an alphanumeric text field that is available for entering data that will print at the bottom of each ticket. You can enter up to 8 lines of footer text, and also insert blank lines between lines of text.

End Shift

Pressing the **End Shift** function key to end the shift. Respond to the prompt “**Are you sure you want to end your shift?**” with either the **Yes** or **No** function keys:

- **No** - Returns the Register back to the Delivery Details screen.
- **Yes** - Prints the end-of-shift ticket if a ticket printer is available and ready.

Diagnostics

Diagnostics screens give you easy access to view real-time diagnostics of the Register. If the printer is available, the you can print a diagnostic ticket. These screens present important system information, as well as on screen visual indications for register state, inputs, outputs and board/sensor status. The diagnostic mode also provides access to the comprehensive list of message data logs that are available in the Register.

Access Restrictions to Diagnostics Screens

User entry into the Diagnostics screens can be restricted either in the Security menu or by establishing a Maintenance Key.

Restricting access in the Security menu

Entry to the **Main** menu, **Setup** menu, or **Diagnostics** Menu can be controlled by selecting one of those options from the **Security** menu and choosing a valid User Key value.

 SECURITY	
Date Format:	MM/DD/YY
Current Date:	06/10/17
Calibration #:	0
Serial ID:	0
Maintenance Key:	1234
User Key:	1234
User Security:	Locked
Select Language:	English
Menu Access Protection:	None
Reset Register Fields:	No
Factory Key:	0
<div style="display: flex; justify-content: space-around;"> Setup Menu Software Update Audit Trail </div>	

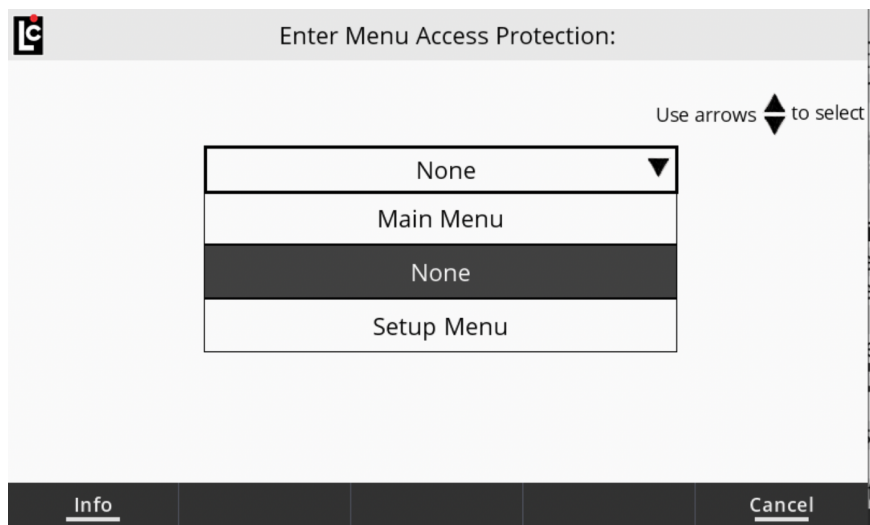

Restrict with a Maintenance Key

Entry into the Diagnostics screen from the Active Delivery screen will be restricted if a valid Maintenance Key has been set. As shown below, the user will be prompted to enter the Maintenance Key if they select the F2 to enter the Diagnostics screen.



Diagnostics Screen 1/7

A number of diagnostic values appear on screen **1/7**:

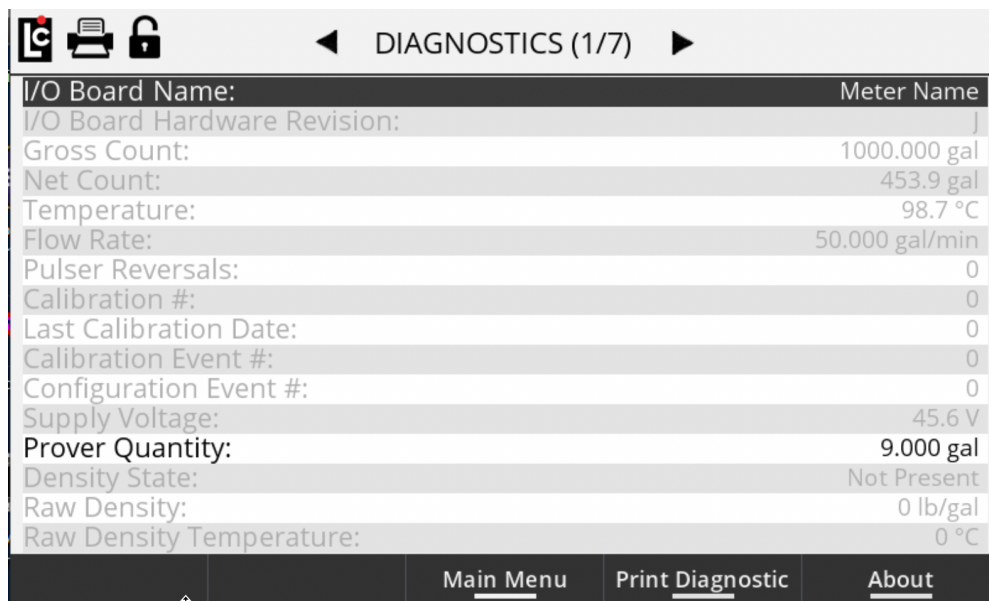

I/O Board Name:	Meter Name
I/O Board Hardware Revision:	
Gross Count:	1000.000 gal
Net Count:	453.9 gal
Temperature:	98.7 °C
Flow Rate:	50.000 gal/min
Pulser Reversals:	0
Calibration #:	0
Last Calibration Date:	0
Calibration Event #:	0
Configuration Event #:	0
Supply Voltage:	45.6 V
Prover Quantity:	9.000 gal
Density State:	Not Present
Raw Density:	0 lb/gal
Raw Density Temperature:	0 °C

Navigation buttons: Main Menu, Print Diagnostic, About

I/O Board Name – A text field that identifies the currently selected I/O board in the **I/O board #** field. The name will also appear on other screens to clearly identify the selected board. **(Maximum - 16 Characters).**

I/O Board Hardware Revision – Board Revision Level.

Gross Count – A read-only field showing the current gross delivery volume displayed on the Register.

Net Count – A read-only field showing the current net delivery volume displayed on the Register.

Flow Rate – A read-only field showing the current flow rate registered by Register during a delivery.

Pulser Reversals – A read-only field that accounts for any quadrature pulser faults registered by the Register during a delivery.

Calibration # – A read-only counter that increments one number each time the Register enters the calibration mode. This field is for metrological and troubleshooting use only.

Last Calibration Date – A read-only field displaying the last date and time the Register entered into the calibration mode.

Calibration Event # – A read-only counter that increments one number each time the Register enters the calibration mode and a calibration change is made. This field only increments one time per entry into calibration even if multiple changes are made. This field is for metrological and troubleshooting use only.

Configuration Event # – A read-only counter that increments one number each time (a) the Register enters the calibration mode and (b) a configuration field changes. This field only increments one time per entry into calibration even if multiple changes are made. This field is for metrological and troubleshooting use only.

Supply Voltage – Current voltage reading of the power supply.

Prover Quantity - The prover quantity for calibrating the meter.

Density State – Indicates if the product density feature is present or not.

Raw Density – Current or last reading of Density (if present).

Density Temperature – Current or last Density reading of product temperature (if present).

Diagnostics Screen 2/7

Register State – a real-time view of the current status of the key Register state fields. This is useful to see if a parameter is active (Yellow), not active (White), or in an error state (Red).

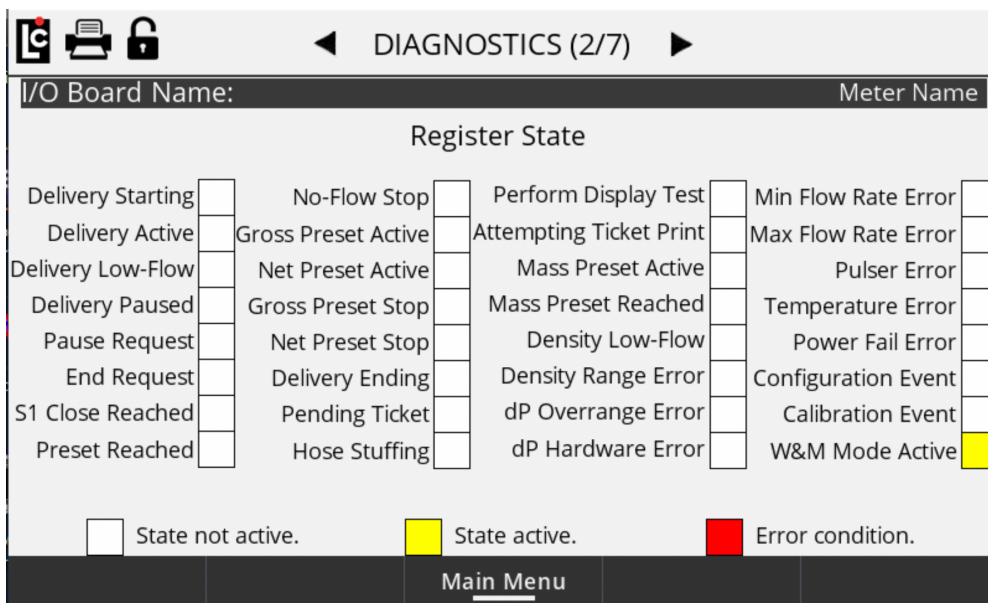

Diagnostics Screens 3/7 and 4/7

I/O Board inputs and outputs appear on screens 3/7 and 4/7. These provide a real-time view of the current status of Register I/O board digital inputs and outputs. These are useful in monitoring inputs and outputs that may have a status of **on** (Yellow), **off** (White), or **error** (Red).

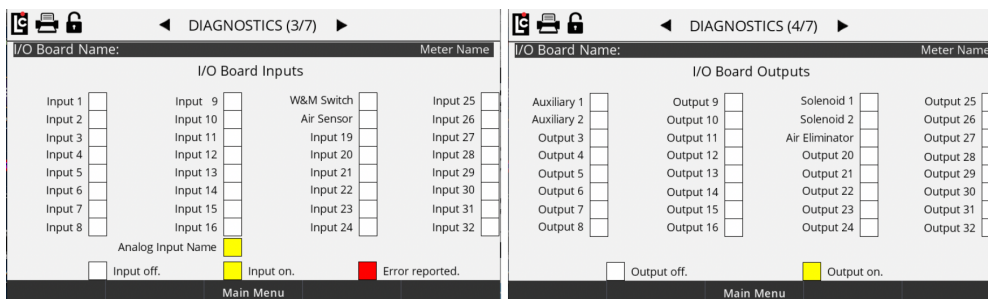

Diagnostics Screen 5/7

Potential error conditions are shown on Diagnostics Screen 5/67 The status will be either **off** (White) or **error** (Red).

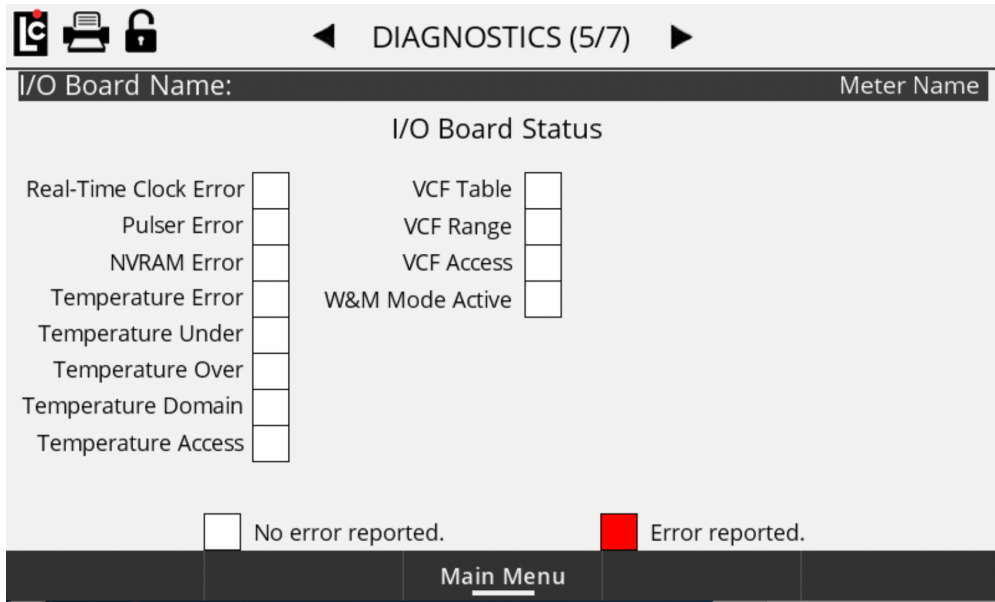

Diagnostics Screen 6/7

This screen monitors status of up to 6 SENSEiQ expansion boards (if installed).

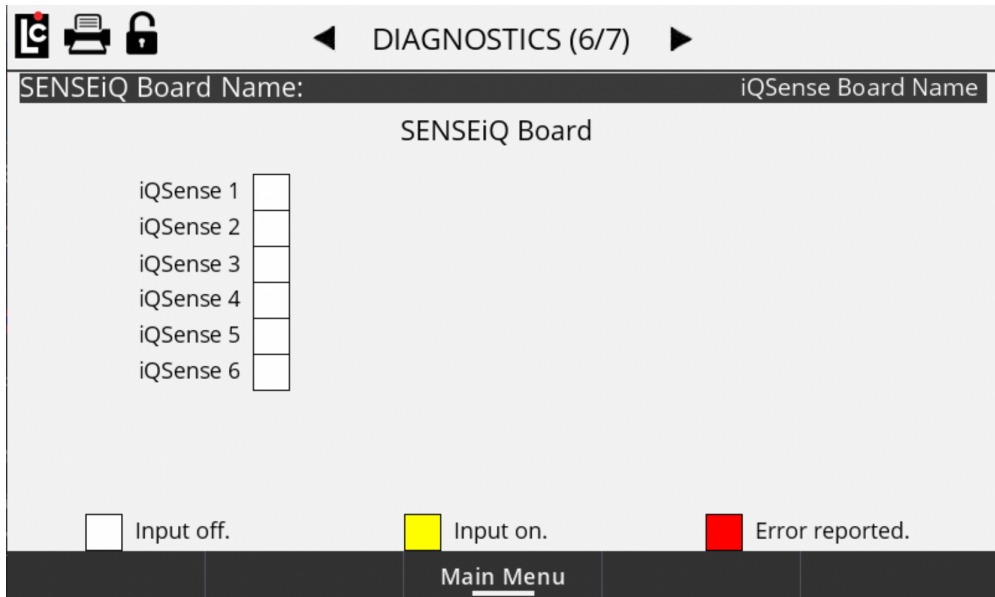

Diagnostics Screen 7/7

Message Logging is a tool within the register that allows a user to pull log files from the register and display, print, and export diagnostic information.

The Message, Smart Pump, and Water Detector logs are viewable and configurable Diagnostics (6/6) screen. However, these settings cannot be changed when the register is unlocked. For both the Smart Pump and Water Detector, the corresponding Services also need to be enabled.

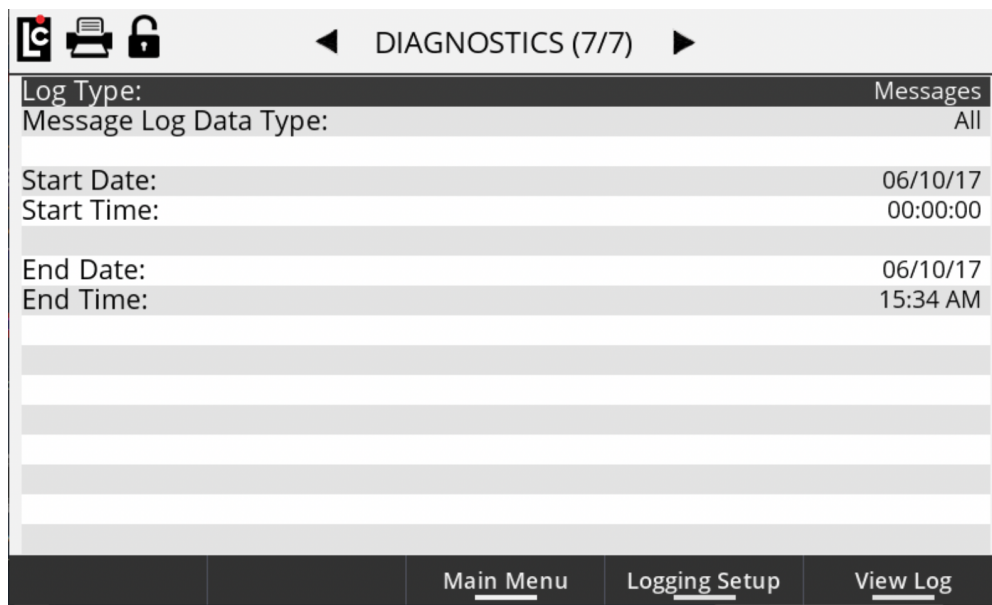

Log Type

A list box that can be used to select a data log that can be viewed on-screen and also printed. Upon selecting **Log Type**, a drop-down menu appears and provides the following log file types you can view.

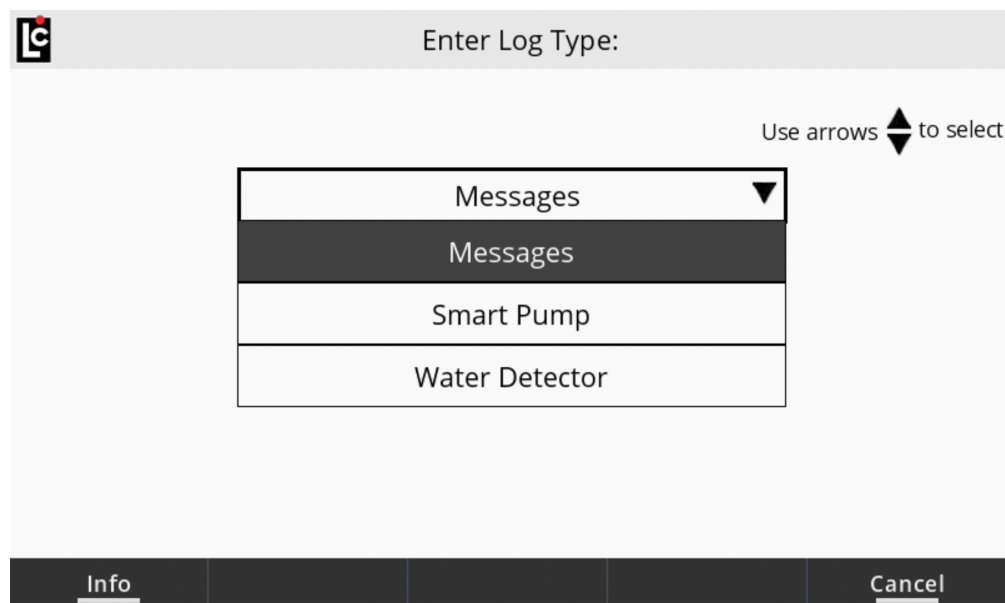

Log Types include the following: Messages, Smart Pump, and Water Detector. To view the Smart Pump and Water Detector log types, the corresponding Services must be enabled, and the logs enabled in **Logging Setup (1/2)**.

If **Messages** is selected for the **Log Type**, you can select a subtype of data specific to the Message Log, and also choose the date range to include in the view.

Message Log Data Types include the following subtypes of data: All, Calibration, Errors, Flow Start/End, Hardware Diagnostics, LCP Diagnostics, Operator Actions, Parameter Changes, Shift Start/End, Software Diagnostics, and Warnings.

Start Date/Time and **End Date/Time** allows you to limit the range of data for the Message Log that you would like to view.

Once a log type is selected, press the function key **View Logs** to display the logs on the screen. Once the log is viewable on the screen, you can press the function key **Print** to print the log (if a printer is installed).

To change the data that is saved to the logs, press the **Logging Setup** function key.

Logging Setup Screens

You cannot modify the settings on this screen if the register is locked. The Smart Pump, Transaction, and Water Detector Logs can be enabled and disabled on the first screen, and Message Log data subtypes can be enabled and disabled on the second screen. A log has been enabled if a check mark appears before its name. Both the Smart Pump and Water Detector logs that you enable the corresponding Service.

To enable/disable a log, use the arrow keys to navigate to the desired line and then press **Enter**. Next, select **Continuous** or **Specific** for **Enter Log Start Date/Time**. If you select **Continuous**, enter the **Log Retain Time**—which is the number of days to retain the log data. If you select **Specific**, enter the **Log Start Date** and the **Log End Date**.

WARNING: If you enable all of the Message Log subtypes, the register will continue to store a lot of data— especially if you also enable **Hardware Diagnostics, Software Diagnostics, and Operator Actions**. We recommend that if you enable all of these options that you either (a) set a **Specific End Time** or (b) set the **Retain** value to a low number of days.

If the Weights & Measures seal screw has been removed, you may use the **Delete Files** function key to delete existing log files—or use the **Copy Files** function key to copy existing log files to a USB drive.

LOGGING SETUP (1/2)				
Log Name	Start Time	End Time	Retain	Size (K)
<input checked="" type="checkbox"/> Smart Pump	Continuous		45 days	0
<input checked="" type="checkbox"/> Transaction	Continuous		365 days	3341
<input checked="" type="checkbox"/> Water Detector	Continuous		50 days	0

Drive Size:	7287280K	Used:	2807252K	Available:	4090140K	Use :	41%
		<u>Close</u>		<u>Delete Files</u>		<u>Copy Files</u>	

Log Name	Start Time	End Time	Retain	Size (K)
<input checked="" type="checkbox"/> Messages			90 days	452998
<input checked="" type="checkbox"/> Errors	Continuous			
<input checked="" type="checkbox"/> Warnings	Continuous			
<input type="checkbox"/> Hardware Diagnostics	Continuous			
<input type="checkbox"/> Software Diagnostics	Continuous			
<input checked="" type="checkbox"/> Flow Start/End	Continuous			
<input checked="" type="checkbox"/> Shift Start/End	Continuous			
<input checked="" type="checkbox"/> Parameter Changes	Continuous			
<input checked="" type="checkbox"/> Calibration	Continuous			
<input type="checkbox"/> Operator Actions	Continuous			
<input type="checkbox"/> LCP	Continuous			

Drive Size:	7287280K	Used:	2806280K	Available:	4091112K	Use :	41%
-------------	----------	-------	----------	------------	----------	-------	-----

Setup Menu

The **Setup Menu** contains a list of menu options for configuring the Register for operation. Typically, the setup menu options are set up when the register is installed or calibrated. Settings that are programmed using the setup menu options will affect how the register will display, print, report and operate. When setting up the Register, it is important to understand how each of these settings affect the Register register and contribute to proper operation for the application.

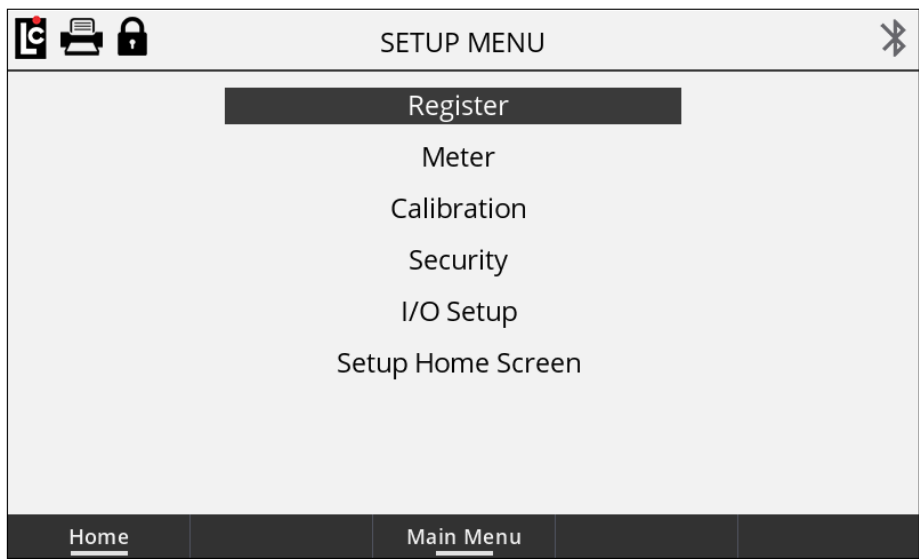

Register Settings

Register menu options can be found on three screens. These parameters are for configuring general functionality of the Register, and how it will interact with components in the system.

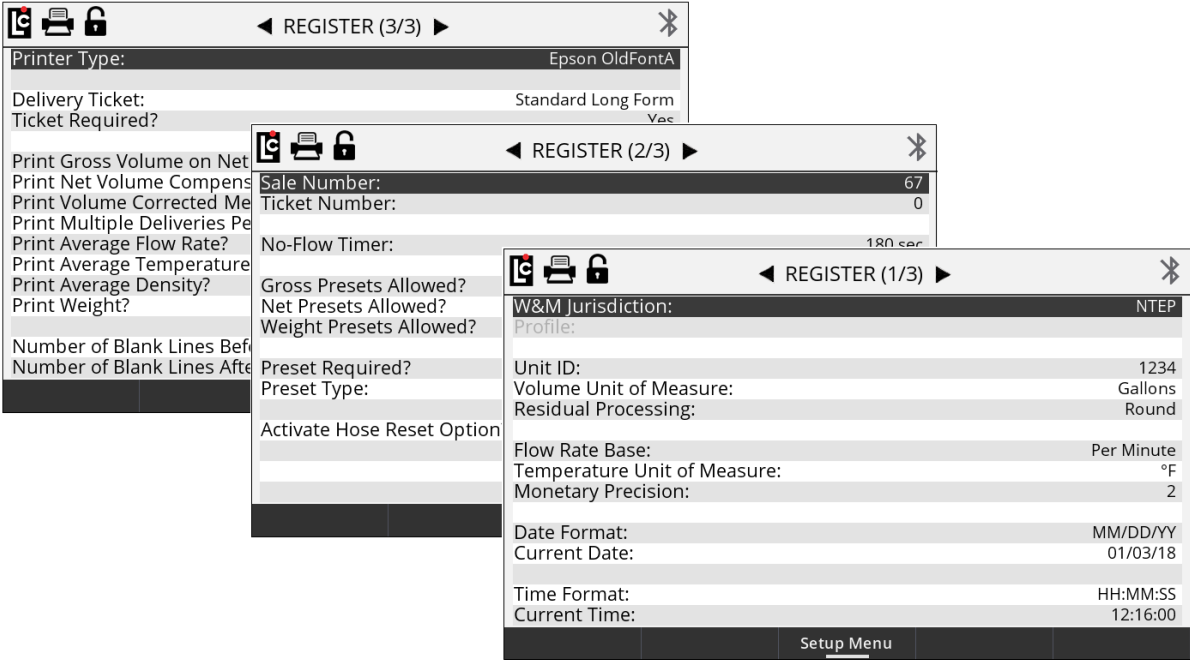

Register (1/3)

W&M Jurisdiction – Selecting the proper local jurisdiction option will automatically adjust the available setup menu options and remove options that are not acceptable based on the selection.

Options:

- NTEP - National Type Evaluation Program - US W&M
- Measurement Canada

Unit ID – A text field for identifying the equipment or meter that the Register is associated with. **(Maximum - 10 alphanumeric characters)**

Volume Unit of Measure – A list box for setting the volumetric unit of measure to be used by the register for flow measurement.

Options:

- Gallon
- Litre
- Cubic Meter
- LB (Pound)
- KG (Kilograms)
- Barrel
- Other

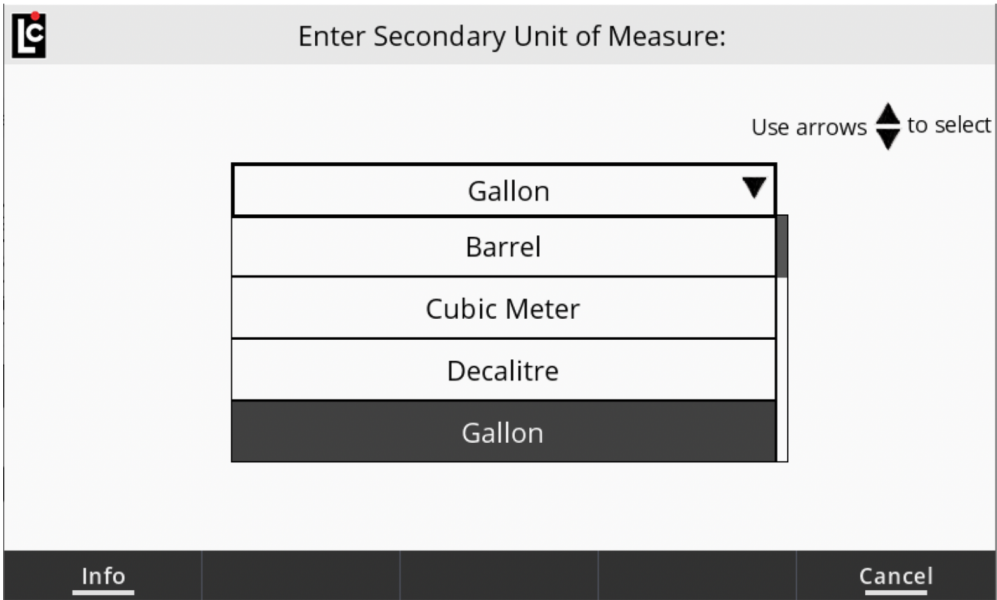

Residual Processing – A list box for selecting how the Register will display volumes less than the least significant digit.

Options:

- Round - Adjust delivery amount to the closest least significant digit.
- Truncate - Throw away the remaining value and always round down.

Flow Rate Base – A list box for selecting the time unit for flow measurement. This field will affect how the unit of flow rate measure will display on the screen—and what appears on printed tickets and transactional records.

Options:

- Per Minute
- Per Hour
- Per Second

Temperature Unit of Measure – A list box for selecting the unit of measure used when a temperature probe is connected to the Register.

Options:

- °F - Fahrenheit
- °C - Celsius

Monetary Unit of Measure – A text field for identifying the type of currency. **(Maximum - 3 alphanumeric characters)**

Monetary Precision – A list box that is used to select the number of decimal places to be used when printing and displaying pricing.

Options:

- 0 (0) - No decimal place
- 1 (0.0) - One digit after the decimal place
- 2 (0.00) - Two digits after the decimal place
- 3 (0.000) - Three digits after the decimal place
- 4 (0.0000) - Four digits after the decimal place

Date Format – A list box that is used to set the format for displaying and printing the Register date.

Options:

- MM/DD/YY - Month/Day/Year
- DD/MM/YY - Day/ Month/Year

Current Date – A fixed data entry field setting the internal calendar of the Register according to the date format field option. The Register will update the calendar automatically according to this setting. The date can be displayed on screen, printed on the ticket, and appear in each transaction record.

Time Format – A list box that is used to set the format for displaying and printing the Register time.

Options:

- HH/MM/SS - Time will display with Hours/Minutes/Second
- AM/PM - Time will display with Hours/Minutes with am or pm

Current Time – A fixed-data entry field for setting the register time clock of the Register according to the time format field option. The Register will update the time according to this setting. The time can be displayed on screen, printed on the ticket, and appear in each transaction record.

Register (2/3)

Sale Number – A numeric-only text field that will automatically increment one digit for each delivery or transaction that is started by the Register. The sale number can be set to any initial numeric value up to 6 digits, and will increment from that value. A new Register will always start from 1. This is a required field on all standard ticket formats.

Ticket Number – A numeric-only text field that will automatically increment one digit for each delivery ticket that is printed by the Register including duplicate tickets of the previous delivery. The ticket number can be set to any initial numeric value up to 6 digits, and will increment from that value. A new Register will always start at ticket number 0 which deactivates the ticket number feature. If deactivated, the ticket number will not increment and will not print on any of the delivery ticket formats.

No Flow Timer – A numeric-only text field that sets a timer (in seconds) to automatically terminate an active delivery (and prints a ticket, when applicable) if no product movement is sensed during the duration of the timer. This timer will not activate until at least one whole unit of volume has been registered by the Register.

Setting this field to 0 will deactivate the No Flow Timer. Also, setting this field to a value of 0 or a value greater than 180 (up to 3600) may activate the “Print Multiple Deliveries Per Site Message”

NOTE: See Register (3/3) to setup the “Print Multiple Deliveries Per Site Message”.

The No Flow Timer can also be toggled on and off (180 to 0) in the Setup Delivery mode by activating the Multiple Deliveries Per Site option in Configure Delivery Setup menu.

Gross Presets Allowed? – A list box that enables or disables the option and the ability to use gross presets when making a delivery.

Options:

- **No** - Gross presets are not allowed
- **Yes** - Gross presets are allowed

Net Presets Allowed? – A list box that enables or disables the option and the ability to use gross presets when making a delivery. Net presets require an ETVC kit to be installed and temperature compensation to be active on the Register.

Options:

- No - Net presets are not allowed
- Yes - Net presets are allowed

Weight Presets Allowed? – A list box that enables or disables the option and the ability to use weight presets during a delivery.

Weight presets require that an automatic density sensor be installed, or otherwise that the manual density entry is active on the Register.

Options:

- **No** - Weight presets are not allowed
- **Yes** - Weight presets are allowed

Price Presets Allowed? – A list box that enables or disables the option and the ability to use price presets when making a delivery. Price presets require the Price/Unit to not be zero.

Options:

- **At Least the Entered Price**
- **No** - Price presets are not allowed
- **No More than the Entered Price**

Preset Required – A list box that specifies a requirement for the user to enter a preset value for every transaction of the Register.

Options:

- **No** - Presets are optional
- **Yes** - Presets are required

Preset Type – A list box that is used to setup how the Register will respond when the preset amount has been reached. These setting options will affect when the end delivery command is sent and also when the ticket will print.

Options:

- **Clear** – At the point the preset value is reached, the delivery automatically ends, the ticket prints, and the preset value is set to 0.
- **Multiple** – At the point the preset value is reached, the delivery is paused but remains active—until the user either presses resume, sets a new preset and presses resume or ends the delivery by pressing the **End & Print** button and the preset value is set to 0.
- **Retain** – At the point the preset value is reached, the delivery automatically ends, the ticket prints, and the preset value that was originally set is retained for the next delivery.

NOTE: See [Operating the Register](#) ¹⁰⁹ for more detail on selecting a preset type.

Activate Hose Reset Options? – A list box for selecting if the **Hose Reset** feature will be active on the Register. When this feature is set to **YES**, the Register will present the onscreen action key **Hose Reset** when the **START** key is pressed. This onscreen action will display until the register has delivered up to 1 gallon (4 Litres), then this key will disappear from the onscreen action options.

Fully-packed hose: To comply with Weights & Measures requirements, it is necessary to start and stop each delivery with a fully packed hose. This will be the case with normal deliveries. However, there are times where the hose is not fully packed (for example, after a preset delivery). As such, the hose must be packed and the register zeroed prior to making the next delivery.

Options:

- **Yes** - Hose reset option is active
- **No** - Hose reset option is not active

NOTE: See [Operating the Register](#)  for more detail on using the hose reset feature.

Register (3/3)

Printer Type – A list box for selecting type of printer connect to the Register—if a printer is necessary.

Options:

- **EPSON NewFontB** - For use with EPSON 220 roll printers
- **EPSON NewFontA** - For use with EPSON TM-T88iii (Wired) and EPSON TM-P80 (wireless Bluetooth) thermal printers
- **EPSON OldFontA** - For use with EPSON 295 Slip printers
- **EPSON OldFontB** - For use with EPSON 300 Roll Printers
- **OKIDATA ML184T** - For use with Okidata ML184T
- **BLASTER** - For use with Cognitive Solutions Thermal Printer

Delivery Ticket – A list box that is used to select the desired Register base ticket format to be used when printing tickets. There are four base ticket formats available, however additional information such as price, tax, header, average temperature, average flow rate, and more can be added to each base ticket format when setting up the Register.

Options:

- **Standard Long Form** - For tickets when a larger area is available for printing more ticket details.
- **Standard Short Form** - For tickets with a small fixed printing area such as a preprinted ticket previously used with mechanical registration.
- **Detailed with Totalizers** - For markets such as terminals and aviation that require start and end totalizers printed on the ticket.
- **Long Form without Time** - For use by 3rd party devices that pass through date/time, and do not require the Register time stamp on the ticket.
- **English/French Long Form** – Similar to the Standard Long Form ticket but with French.
- **English/French Short Form** - Similar to the Standard Short Form ticket but with French.
- **English/French Custom** – For specific Canadian markets.
- **No Ticket** - When Register will not print any ticket. However, a 3rd party may still pass-through print information by means of the LCP communication protocol.

Standard Long Form (Minimum Options)

```

START          10/30/18 08:15:12
FINISH         10/30/18 08:21:15

START COUNT    0.0 GALLONS
END GROSS COUNT 100.0 GALLONS
GROSS DELIVERY 100.0 GALLONS
1993 REG. GASOLINE GASOLINE 1
SALE NUMBER    2232
METER NUMBER   368251
UNIT ID        TR3526
    
```

Detailed with Totalizers (Minimum Options)

```

SALE NUMBER    2232
TIME START     10/30/18 08:15:12
TIME END       10/30/18 08:21:15
START COUNT    0.0 GALLONS
END GROSS COUNT 100.0 GALLONS
GROSS DELIVERY 100.0 GALLONS
1990 REG. GASOLINE GASOLINE 1
START TOTALIZER 2563215.1 GALLONS
END TOTALIZER  2563315.1 GALLONS
    
```

Standard Short Form (Minimum Options)

```

SALE# 2251 DATE 10/30/18 08:15:12
COUNT: START 0.0 END 100.0
GROSS DELIVERY 100.0
1993 REG. GASOLINE GASOLINE 1
    
```

Long Form without Time (Minimum Options)

```

DATE          10/30/18
START COUNT   0.0 GALLONS
END GROSS COUNT 100.0 GALLONS
GROSS DELIVERY 100.0 GALLONS
1993 REG. GASOLINE GASOLINE 1
    
```

In the ticket options shown above, the minimum amount of information available is shown for each format type. Information such as ticket headers, pricing, and ticket number are options

that will print on any of these formats—if data is entered into the appropriate fields. Also, there are additional fields listed in the options below that can print on all of the above tickets (when enabled).

Ticket Required? – A list box for choosing whether or not a ticket is necessary to start a delivery. In most cases, Weights & Measures-governed truck applications will require a printed ticket for each transaction.

Options:

- **Yes** - The previous delivery ticket must be printed completely, a new ticket must be in place and the printer ready in order to begin a delivery.
- **No** - No ticket is required to begin a delivery. However, if a ticket printer and ticket are in place, then the Register will be able to print.

Print Gross Volume on Net Deliveries? – A list box used to add a printed line(s) to the delivery ticket showing the Gross Delivery information along with the Net Delivery information when temperature compensation is active. If temperature compensation is not active, all delivery amounts will automatically be Gross Delivery amounts. If using the ticket format Detailed with Totalizers, the Gross Totalizers will also be printed with the Net Totalizers when active.

Options:

- **Yes** - Prints line(s) on the ticket showing the Gross Delivery information
- **No** - No additional line(s) are printed

```

SALE # 2251 DATE 10/30/18 8:15:29
COUNT: START 0.0 END 100.0
GROSS DELIVERY 101.5 GALLONS
NET DELIVERY 100.0 GALLONS
1075 PROPANE LPG 1
TABLE 24 SG 0.505
VOLUME CORRECTED TO 60 DEG F

```

Print Net Volume Compensation Parameter? – A list box for adding a printed line to the delivery ticket that shows the selected temperature compensation table and parameter that are currently in use by the Register.

Options:

- **Yes** - Prints a line on the ticket showing compensation table and parameter
- **No** - No additional line is printed

```

SALE # 2251 DATE 10/30/18 8:15:29
COUNT: START 0.0 END 100.0
GROSS DELIVERY 101.5 GALLONS
NET DELIVERY 100.0 GALLONS
1075 PROPANE LPG 1
TABLE 24 SG 0.505
VOLUME CORRECTED TO 60 DEG F

```

Print Volume Corrected Message? – A list box for adding a printed line to the delivery ticket that shows the product selected is volume-corrected to the selected base temperature of the compensation table. Typical settings for base temperature at 60 °F / 15 °C—depending on the selected compensation table. However, some tables may vary.

Options:

- **Yes** - Prints a line on ticket showing the VOLUME CORRECTED TO message
- **No** - No additional line is printed

```
SALE # 2251 DATE 10/30/18 8:15:29
COUNT: START 0.0 END 100.0
GROSS DELIVERY 101.5 GALLONS
NET DELIVERY 100.0 GALLONS
1075 PROPANE LPG 1
TABLE 24 SG 0.505
VOLUME CORRECTED TO 60 DEG F
```

Print Multiple Deliveries Per Site Message? – A list box for adding a printed line to the delivery ticket showing that multiple deliveries were made at a site. This message will print only if the **No Flow Timer** is set to value of 0 seconds or greater than 180 seconds. This line will also print if the **Select Multiple Delivery** is an active option in the **Setup Delivery** mode.

Option:

- **Yes** - Prints line on ticket: **MULTIPLE DELIVERIES AT ONE SITE**
- **No** - No additional line is printed

```

SALE # 2251 DATE 10/30/18 8:15:29
COUNT: START 0.0 END 100.0
GROSS DELIVERY 101.5 GALLONS
NET DELIVERY 100.0 GALLONS
1075 PROPANE LPG 1
TABLE 24 SG 0.505
VOLUME CORRECTED TO 60 DEG F
- MULTIPLE DELIVERIES AT ONE SITE -
    
```

Print Average Flow Rate? – A list box for adding a printed line to the delivery ticket showing the average flow rate throughout the duration of a delivery transaction.

Options:

- **Yes** - Prints line on the ticket displaying the **AVERAGE FLOW RATE**
- **No** - No additional line is printed

```

SALE NUMBER 2232
TIME START 10/30/18 08:15:12
TIME END 10/30/18 08:21:15
START COUNT 0.0 GALLONS
END GROSS COUNT 100.0 GALLONS
GROSS DELIVERY 100.0 GALLONS
1990 REG. GASOLINE GASOLINE 1
AVERAGE FLOW RATE 86.5 GAL/MIN
AVERAGE TEMPERATURE 63.7 DEG F
START TOTALIZER 2563215.1 GALLONS
END TOTALIZER 2563315.1 GALLONS
    
```

Print Average Temperature? – A list box for adding a printed line to the delivery ticket showing the average temperature throughout the duration of a delivery transaction.

Options:

- **Yes** - Prints line on the ticket showing the AVERAGE TEMPERATURE
- **No** - No additional line is printed

SALE NUMBER	2232
TIME START	10/30/18 08:15:12
TIME END	10/30/18 08:21:15
START COUNT	0.0 GALLONS
END GROSS COUNT	100.0 GALLONS
GROSS DELIVERY	100.0 GALLONS
1990 REG. GASOLINE	GASOLINE 1
AVERAGE FLOW RATE	86.5 GAL/MIN
AVERAGE TEMPERATURE	63.7 DEG F
START TOTALIZER	2563215.1 GALLONS
END TOTALIZER	2563315.1 GALLONS

Print Average Density? – A list box for adding a printed line to the delivery ticket showing the average density throughout the duration of a delivery transaction.

Options:

- **Yes** - Prints line on the ticket showing the AVERAGE DENSITY
- **No** - No additional line is printed

SALE NUMBER	2232
TIME START	10/30/18 08:15:12
TIME END	10/30/18 08:21:15
START COUNT	0.0 GALLONS
END GROSS COUNT	100.0 GALLONS
GROSS DELIVERY	100.0 GALLONS
1990 REG. GASOLINE	GASOLINE 1
AVERAGE DENSITY	6.758 LBS/GAL
WEIGHT (REF.)	675.8 LBS
START TOTALIZER	2563215.1 GALLONS
END TOTALIZER	2563315.1 GALLONS

Print Weight? – A list box for adding a printed line to the delivery ticket showing the weight (reference) of a delivery transaction.

Options:

- **Yes** - Prints line on the ticket showing the WEIGHT (REFERENCE)
- **No** - No additional line is printed

SALE NUMBER	2232
TIME START	10/30/18 08:15:12
TIME END	10/30/18 08:21:15
START COUNT	0.0 GALLONS
END GROSS COUNT	100.0 GALLONS
GROSS DELIVERY	100.0 GALLONS
1990 REG. GASOLINE	GASOLINE 1
AVERAGE DENSITY	6.758 LBS/GAL
WEIGHT (REF.)	675.8 LBS
START TOTALIZER	2563215.1 GALLONS
END TOTALIZER	2563315.1 GALLONS

Number of Blank Lines Before Ticket – A numeric-only text field that will print (feed) blank lines on all tickets prior to printing any of the Register printer text. Typically, this helps to align a ticket when using a slip printer. **(Maximum - 20 lines)**

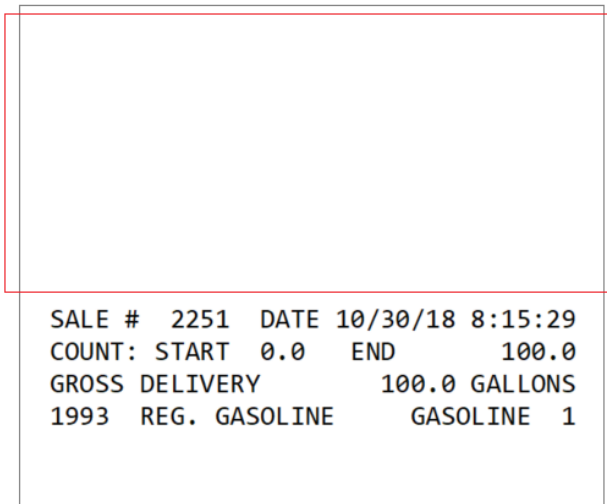

Number of Blank Lines After Ticket – A numeric-only text field that will print (feed) blank lines on all tickets after printing the last line of text send to the Register. With roll printers, this typically helps to feed the roll paper beyond the razor used to remove the ticket. **(Maximum - 20 lines)**

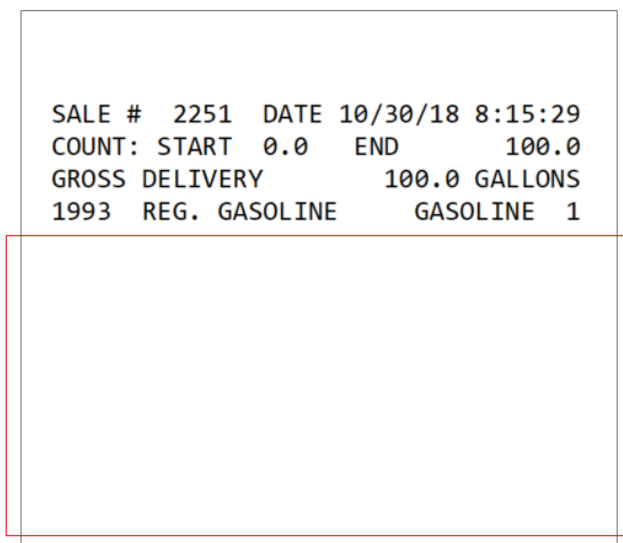

Meter Settings

Meter menu options allow the user to set up information specific to the meter that is connected to the Register. It will be identified by the I/O Board #, UID, and Name fields.

I/O Board Name:	
IO Board UID:	3233353434375117002D0039
Meter ID:	
Pulser Input Type:	Dual Channel
Flow Direction:	==>
Pulser Input Mode Between Deliveries:	Count Forward and Reverse
HEPCV In Use?	No
Decimal Digits:	Tenths
Temperature:	70.89 °F
Temperature Offset:	0.00 °F

Setup Menu

Meter (1/3)

I/O Board# – A numeric-only text field for identifying an I/O board that is connected to the Register. Settings for the each I/O board can be made when the selected I/O board appears in this field. The main I/O board in the Register is always I/O board 0. **(Maximum setting is currently 0)**

I/O Board UID – This read-only fields displays the serial number of the I/O board# that is currently selected.

I/O Board Name – A text field for identifying the currently selected I/O board in the I/O board # field. The name will also appear in other screens to clearly identify the selected board. **(Maximum - 16 alphanumeric characters)**

Meter ID – A text field for identifying a meter that is connected to the Register, Typically, the serial number of the meter is entered here. The value of this field is also printed on the Register calibration ticket. **(Maximum - 10 alphanumeric characters)**

Pulser Input Type – A list box for selecting the type of pulse input signal that will be connected to the selected I/O board.

Options:

- **Dual Channel** - 2 channel quadrature pulser signal such as the Register internal pulser or a POD pulser.
- **All Single Channel** - Single channel square wave signal
- **Triple Channel** - 3 channel pulser square wave signal
- **None** - No pulser is connected to the Register

Flow Direction – A list box field for inverting the direction of flow within the Register. If the register is counting in the reverse direction when first installed, inverting the flow direction will cause the register to count in the opposite direction.

Options:

- ==>
- <==

Pulser Input Mode Between Deliveries – A list box field for specifying how the Register will respond to any registered pulse signal when the register is not in an active delivery.

Options:

- **Count Forward and Reverse** - A registered pulse signal—either forward or reverse—will directly affect the accumulative totalizer readings. It will also display the volume on the idle delivery screen.
- **Forward Count Only** - A registered pulse signal, in the forward direction only, will directly affect the accumulative totalizer readings. It will also display the volume on the idle delivery screen.
- **Ignore** - Any pulse signal that is detected when a delivery is not active will be ignored by the Register.

- **Reverse Count Only** - A registered pulse signal, in the reverse direction only, will directly affect the accumulative totalizer readings. It will also display the volume on the idle delivery screen.

HEPCV In Use? – A list box for enabling or disabling the Hose End Press Control Valve. This feature is to be enabled only when using a hose end press control valve in an aviation fueling system. This feature is designed to reduce back pressure and flow surges in the system.

Options:

- **Yes** – Enables HEPCV
- **No** – Disables HEPCV

Decimal Digits – A list box field that sets the decimal place for the displayed volume and also the shift and accumulative totalizers.

Options:

- **Whole** - Sets the decimal place to the whole units position (xxxxxx)
- **Tenths** - Sets the decimal place to the tenth unit position (xxxxx.x)
- **Hundredths** - Sets the decimal place to the hundredths position (xxxx.xx)
- **Thousandths** – Sets the decimal place to the thousandths position (xxx.xxx)

Temperature – This numeric-only text field displays the current temperature sensed by the Register temperature probe when installed. Use this field to set a temperature offset, if the value is within the allowed range of the temperature offset field below. If no probe is installed, this value will read --.- .

Temperature Offset – A numeric-only text field for specifying an offset to the value of the current temperature reading. A value of +/- .54 degrees F or +/- .3 degrees C is allowed by Weights and Measures. When an offset is entered and within the acceptable range, the current

temperature will automatically be adjusted by the amount of this value. **(Floating point from -.30 to +.30°C or -.54 to +.54°F)**

Meter (2/3)

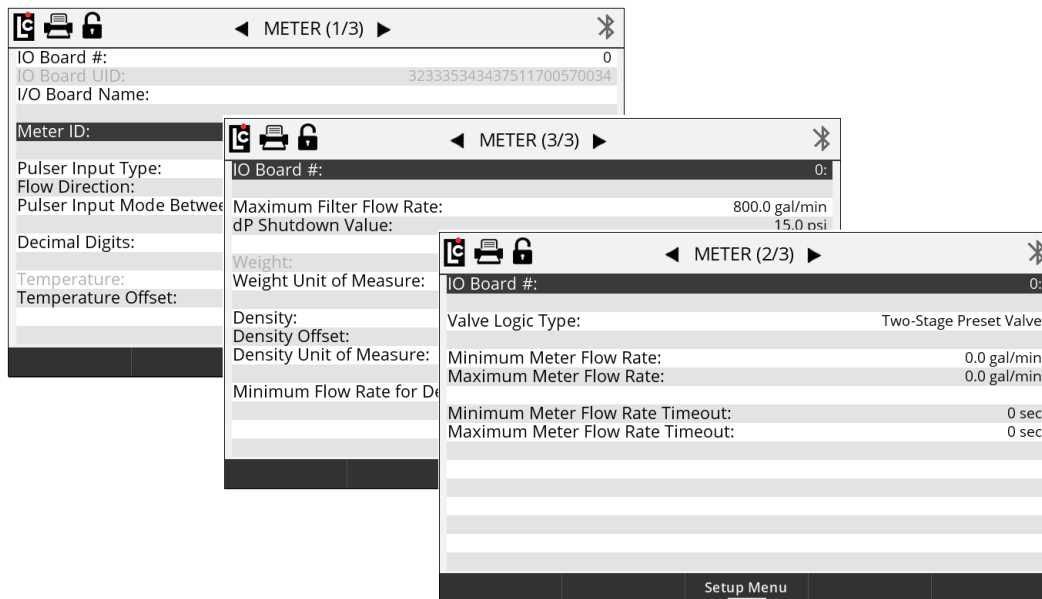

Valve Logic Type – A list box field that is used to select the logic to be used when connecting a solenoid valve to the Register.

Options:

- **Two-Stage Preset Valve** - This logic is to be used with standard 2 stage preset valves. With this logic, only S1 will open for full flow when a delivery starts. S2 will only open for dwell (slow) flow. This logic is the same as in the LCR-II and LCR 600 registers.
- **Single/Dual Option Preset Valve** - This logic can be used when using single or dual stage preset valves. With this logic both S1 and S2 will energize at the start of a delivery. If an S1 close time is set, S1 will drop out when the S1 close is reached and S2 will remain open until the final closure amount reached.

Two-Stage Preset Valve Logic

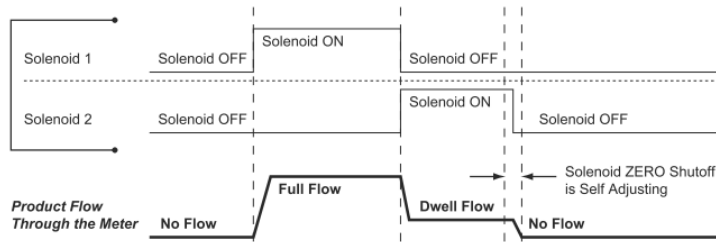

Single/Dual Option Preset Logic (Single Stage)

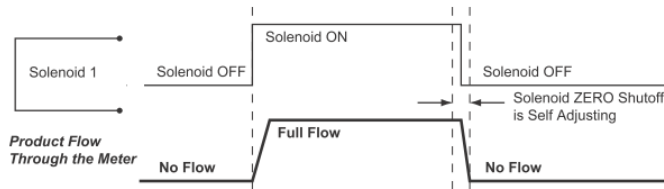

Single/Dual Option Preset Logic (Dual Stage)

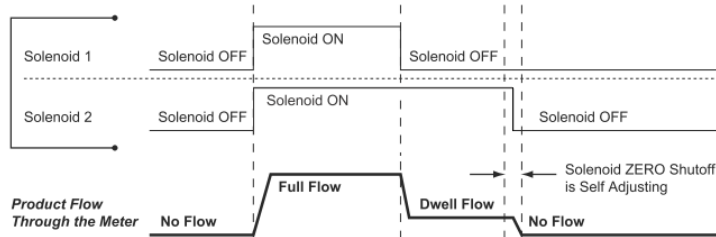

Minimum Meter Flow Rate – A numeric text field that can be used to set a minimum flow rate value for the Register. If the delivery flow rate drops below this value for a duration greater than the Minimum Flow Rate Timeout value, the delivery will be paused by the register and an error message generated to inform the user that the Minimum Flow Rate was detected. **(Maximum - 6 numeric characters)**

Maximum Meter Flow Rate – A numeric text field that can be used to set a maximum flow rate value for the Register. If the delivery flow rate rises above this value for a duration greater than the Maximum Flow Rate Timeout value, the delivery will be paused by the register and an error message generated to inform the user that the Maximum Flow Rate was exceeded. **(Maximum - 6 numeric characters)**

Minimum Meter Flow Rate Timeout – A numeric text field that can be used to set the timeout duration for the minimum flow rate. This is the amount of time, in seconds, that the minimum

flow rate can drop below the set Minimum Flow Rate valve before the delivery pauses.

(Maximum setting - 15 sec)

Maximum Meter Flow Rate Timeout – A numeric text field that can be used to set the timeout duration for the maximum flow rate. This is the amount of time, in seconds, the maximum flow rate can rise above the set Maximum Flow Rate valve before the delivery pauses. **(Maximum setting - 15 sec)**

Meter (3/3)

The screenshot displays three overlapping configuration screens for a meter. The top screen, 'METER (2/3)', shows 'IO Board #' set to 0 and 'Valve Logic Type' as 'Two-Stage Preset Valve'. The middle screen, 'METER (1/3)', shows 'IO Board #' as 0, 'IO Board UID' as 323335343437511700570034, and 'I/O Board Name'. The bottom screen, 'METER (3/3)', shows 'IO Board #' as 0 and various flow and density settings:

Maximum Filter Flow Rate:	800.0 gal/min
dP Shutdown Value:	15.0 psi
Weight:	0.0 lbs
Weight Unit of Measure:	lbs
Density:	0.000 lbs/gal
Density Offset:	0.000 lbs/gal
Density Unit of Measure:	lbs/gal
Minimum Flow Rate for Density:	0.0 gal/min

At the bottom of the 'METER (3/3)' screen is a 'Setup Menu' button.

Maximum Filter Flow Rate – A numeric only text field that is used along with a Liquid Controls Differential Pressure Transducer (dP) to calculate corrected differential pressure based on the maximum rated flow rate of the filter vessel. This field should be set to the maximum flow rate rated on the filter housing. This option only applies when a Liquid Controls dP transducer is connected to the Register. **(Maximum setting - 9999.9)**

dP Shutdown Value – A numeric only text field that should be set to the maximum differential pressure allowed (JIG Standard 15 PSI) when using the Liquid Controls Differential Pressure Transducer. This option only applies when a Liquid Controls dP transducer is connected to the Register. The maximum setting is 60 psi (The Current JIG standard is 15 PSI)

Weight – A read only field that displays a weight value when using Liquid Controls Automatic Density Sensor or entering a manual density value into the Register.

Weight Unit of Measure – A list box field that is used to select the unit of measure for weight when using this feature.

Options:

- **kgs** - Kilograms
- **lbs** - Pounds

Density – A numeric only text box that can either have a density value manually entered or automatically generated using the Liquid Controls Automatic Density Sensor. The maximum setting is 999.999

Density Offset – A numeric only text box that can be used to add an offset to the value measured by the Automatic Density Sensor when installed. This setting has a fixed adjustment of +/- 0.8 units.

Density Unit of Measure – A list box field that is used to select the unit of measure for density when using this feature.

Options:

- **kg/L** - Kilograms per Litre
- **kg/bbl** - Kilograms per Barrel
- **kg/gal** - Kilograms per Gallon
- **kg/m³** - Kilograms per Meter Cubed
- **lb/L** - Pounds per Litre
- **lb/bbl** - Pounds per Barrel
- **lb/gal** - Pounds per Gallon
- **lb/m³** - Pounds per Meter Cubed

Minimum Flow Rate Density – A numeric text box that can be used to set a minimum acceptable flow rate value when calculating density. This value will vary according to the acceptable minimum flow rate of the meter and should never be set below the minimum rated volumetric flow rated on the meter. **(Maximum setting - 999999 Units)**

Calibration Settings

Calibration menu options allow the user to set up and calibrate up to 16 specific products for delivery on the Register. There are four Calibration Settings screens.

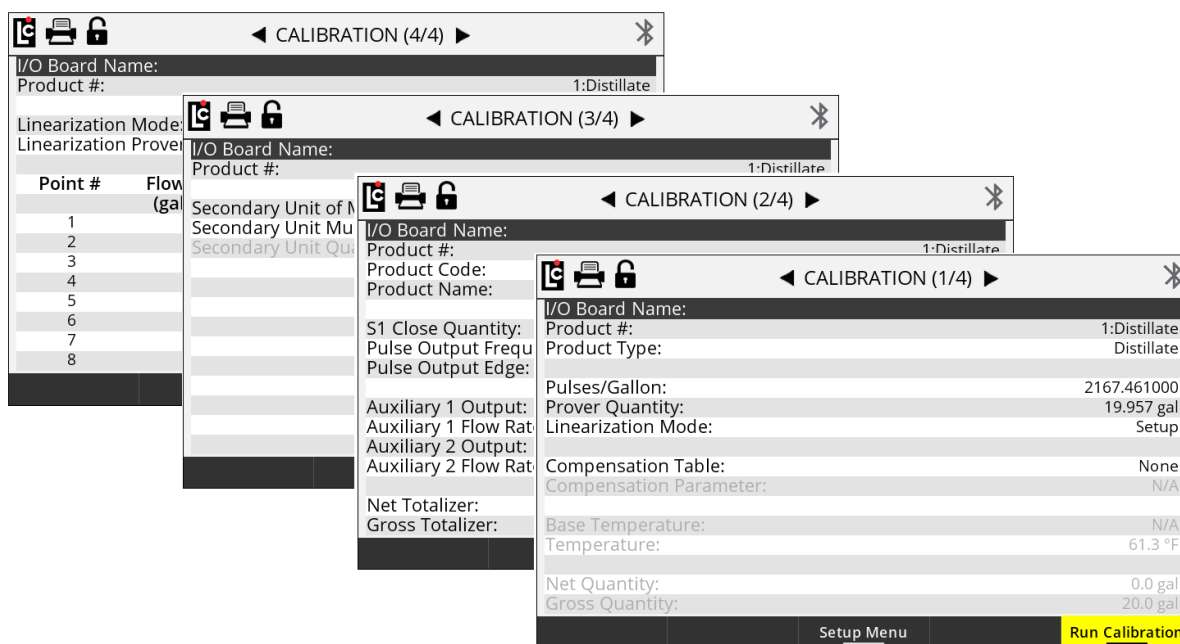

Calibration (1/4)

IO Board Name – A text field that is used to identify the currently selected I/O board in the I/O board # field. The name will display on other screens as well to clearly identify the selected board. **(Maximum - 16 Alphanumeric characters)**

Product # – A list box containing the 16 products that are available for setup and calibration with the Register.

Options:

- **Products 1-16 are available for setup.** Only setup and calibrate products that are to be used by the Register.

Product Type – A list box for selecting the product (classification) type. The product type will print on all calibration and diagnostic tickets and it will designate the Product Type for each Product Number. The product type will also appear on all delivery tickets to assist in identifying the delivered product.

Options:

- Ammonia
- Aviation
- Distillate
- Gasoline
- LPG
- Lube Oil
- Methanol
- Blank

Pulses/Unit (Gallon, Liter...) – A numeric-only text field for specifying the number of pulses that equal the whole-unit of measure for the product being setup on the Register. This number is most important, since it directly affects the calibration of the meter. **(Maximum setting - 20000.00000 units)**

NOTE: A [chart of starting reference calibration factors](#)¹³³ can be found in an appendix to this manual. Refer to this chart for assistance in selecting a starting Pulses/Unit number.

Prover Quantity – A numeric-only text field for calibrating the product currently being set up. This field is used during calibration to enter the known prover quantity of a volumetric proving device or master meter. After a calibration run, entering a value into this field will automatically adjust the **Pulse/Unit** field by the percent error that is calculated. Learn more in [Single-point Calibration](#)¹¹⁶.

Linearization Mode – A list box for applying multi-point calibration, when such calibration is in use. Setting this field to **Applied** will activate multi-point calibration, if all parameters have been met for using multi-point calibration. For instructions on how to perform multi-point calibration, see [Multi-point Calibration](#)¹¹⁷.

Compensation Table – A list box for selecting and using temperature compensation on a product that is being set up. See the Compensation Types and Parameter chart below for details of each table.

Options:

- **None** - Select None if no temperature compensation is to be used
- **Table 24** - Select this table for LPG (USA)
- **Table 54/54E** - Select this table for LPG (Canada and Europe)
- **Table 54B** - Select this table for Refined Petroleum (Canada and Europe)
- **Table 54C** - Select this table for Specialized Products (Canada and Europe)
- **Table 54D** - Select this table for Lube Oil (Canada and Europe)
- **Table 6B** - Select this table for Refined Petroleum (USA)
- **Linear C** - Select this table for a general Linear table when measuring Celsius
- **Linear F** - Select this table for a general Linear table when measuring Fahrenheit
- **NH3** - Select this table for measuring Ammonia (Canada)

Product	VCF Type	Parameter	iQ Parameter Range	iQ Fluid temp. range
General (at 15 °C)	Linear	Coefficient of Thermal Expansion (per °C)	0 to 0.0025	-90 °C to 100 °C
General (at 60 °F)	Linear	Coefficient of Thermal Expansion (per °F)	0 to 0.0045	-130 °F to 212 °F
LPG (at 60 °F)	Table 24	Relative Density (Specific Gravity - SG)	0.500 to 0.550	-50 °F to 140 °F
LPG (at 15 °C)	API Table 54/54E	Density (kg/m ³)	500 to 600	-46 °C to 60 °C
Refined Products (at 60 °F)	API Table 6B	API Gravity (°API)	0 to 85	-50 °F to 200 °F
Refined Products (at 15 °C)	API Table 54B	Density (kg/m ³)	653 to 1075	-50 °C to 95 °C
Specialized Products (at 15 °C)	API Table 54C	Coefficient of Thermal Expansion (per °C)	0.000486 to 0.001674	-50 °C to 95 °C
Lube Oil (at 15 °C)	API Table 54D	Density (kg/m ³)	801.3 to 1163.8	-50 °C to 95 °C
NH ³ (at 15 °C)	NH3 Table	Density (kg/m ³)	617.7 (fixed)	-30 °C to 40 °C

Compensation Parameter – A numeric-only field whose parameter is dependent on the Register Parameter Range listed in the compensation table that was chosen in the list box.

Base Temperature – A numeric-only field that sets the base temperature according to the Register compensation table that was chosen in the list box.

Temperature – A read-only text field that displays the current temperature of the Register—if a temperature probe is connected.

Net Quantity – A read-only text field that displays the current net volume of the last delivery made with the Register. If temperature compensation is not active, this field will not increment.

Gross Quantity – A read-only text field that displays the current gross volume of the last delivery made with the Register.

Calibration (2/4)

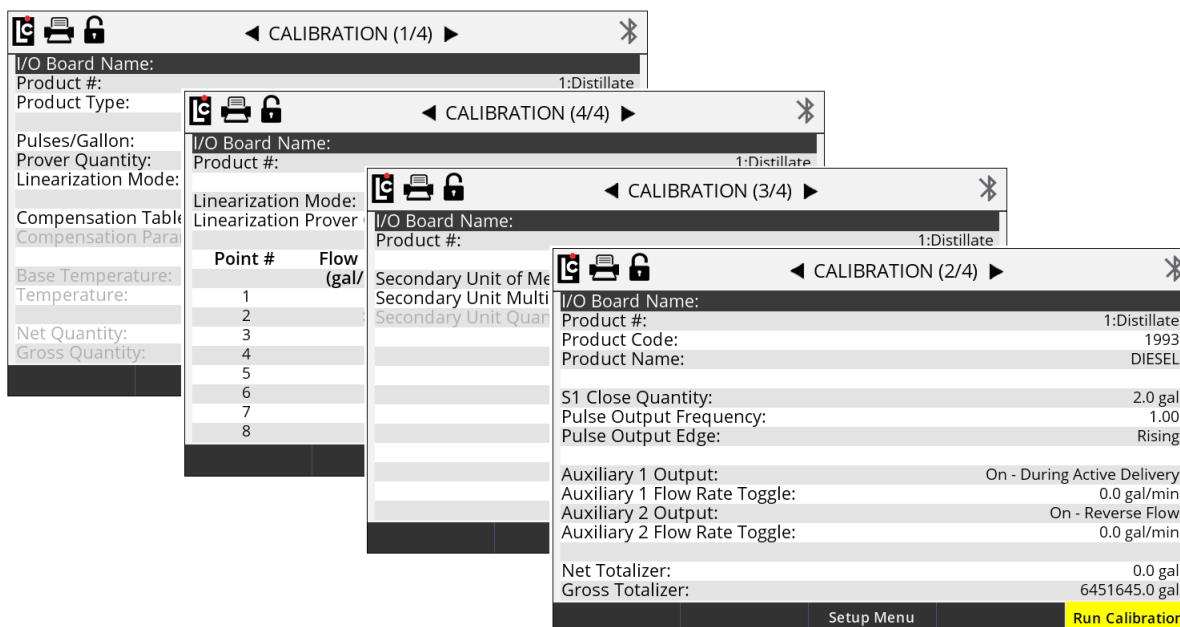

Product # – A list box that list the 16 products that are available for setting up and calibrating the Register.

Options:

- **Products 1-16 are available for setup.** Only setup and calibrate products that are to be used by the Register.

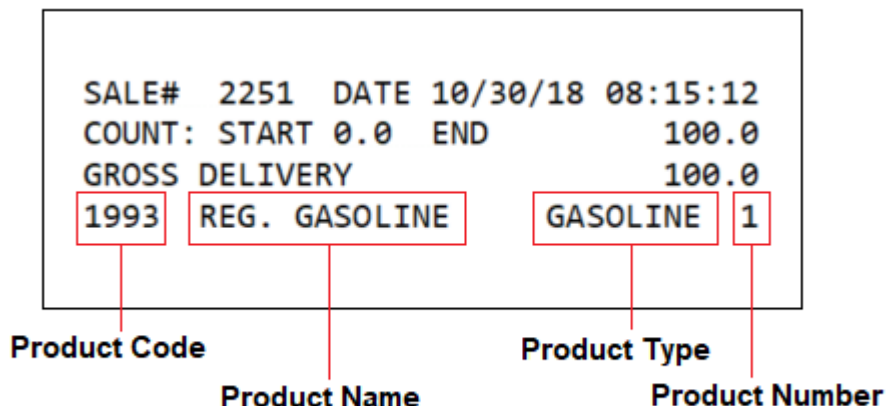

Product Code – A text field for identifying the selected product with a code. The product code will appear on all ticket formats to identify the product that was delivered, as shown above. **(Maximum - 5 alphanumeric characters)**

Product Name – A text field for identifying the selected product with a specific name. The product name will appear on all ticket formats to identify the product that was delivered as shown above. **(Maximum - 18 alphanumeric characters)**

S1 Close Quantity – A numeric text field that is used with 2 stage preset valves. This value sets the number based on the unit of measure that will transition a 2 stage valve from high flow to low flow—for an accurate preset stop. For more information on setting up the S1 closure, see [Setting the S1 Close time](#)¹²⁰. **(Maximum - 5 alphanumeric characters)**

Pulse Output Frequency – A numeric text field that determines the number of output pulses per unit of measure when using the calibrated pulse output feature of the Register. Setting this field to 1 will result in a 1:1 pulse output to the unit of measure. The maximum value that can be set for this field will vary depending on the decimal setting for the unit of measure and the K-Factor (Pulses/Unit) of the product.

- **Hundredths** - Max 1% of the K-Factor
- **Tenths** - Max 10% of the K-Factor
- **Whole** - Max 50% of the K-Factor

Pulse Output Edge – A list box that determines the signal direction of the calibrated pulse output. Toggling this setting can help align the pulse output of the Register with a remote

counter or injection system by inverting the output square wave resulting in an opposite adjustment in the signal.

Options:

- **Rising** - The pulse output square wave from the Register
- **Falling** - The inverted pulse output square wave from the Register

Auxiliary 1 Output – A list box that determines how any digital output that is set to AUX 1 will operate based on the selected product on the Register. There are several features in the Register that can be performed based on the Aux settings to control external components such as pumps, injectors, PTO, throttle, alarms, reset pulse, etc.

Options:

- **Off** - Any output set to AUX 1 Calibration Mode Settings will always be off (Not active)
- **On** - Any output set to AUX 1 Calibration Mode Settings will always be on (Active and Sinking to ground)
- **On - During Active Delivery** - Any output set to AUX 1 Calibration Mode Settings will turn on (Sink to ground) when a delivery is started and will turn off when End is pressed and the delivery is complete.
- **On - During Run State** - Any output set to AUX 1 Calibration Mode Settings will turn on (Sink to ground) when a delivery is active and not paused. The output will be on when a delivery starts. However, if the delivery is paused by issuing a stop command, the output will turn off until the resume command is given. If the end of delivery command is given, the output will remain off and the delivery will end.
- **On - Flow Rate Monitor** - Any output set to AUX 1 Calibration Mode Settings will be on when a delivery is active, however it will deactivate if the flow rate meets or exceeds 40 units/time. If the flow rate does not meet or exceed 40 units/time, the output will remain on.
- **On - Reverse Flow** - Any output set to AUX 1 Calibration Mode Settings will be off when a delivery starts, and will only turn on when the register detect flow in the negative or reverse direction.
- **Reset Pulse/Delivery Start** - Any output set to AUX 1 Calibration Mode Settings will output a short pulse at the start of a delivery that is used with 3rd party remote counters that require a reset pulse to reset to 0.0.

- **Toggle Flow Rate** - Any output set to AUX 1 Calibration Mode Settings will turn on once the flow rate of the Register exceeds the set flow rate point in the Auxiliary 1 Flow RateToggle field below.
- **Calibrated Scaled Pulse Output** - Any output set to AUX 1 Calibration Mode Settings will output a calibrated pulse output—that is scaled according to the Pulse Output Frequency setting in the calibration mode.

Auxiliary 1 Flow Rate Toggle – A numeric text field that can be used to program a flow rate set point when the Aux 1 is set to Toggle flow rate. Auxiliary 1 remains activated above the set flow rate value and deactivates when the flow rate falls below the value.

A common use for this output is an air operated valve (AOV) on the pump. When the flow rate value is attained, the AOV is activated and switches the pump from low-bypass pressure mode to full-flow fuel mode (high bypass pressure). When the flow rate falls below the set value, the AOV deactivates and the pump returns to low flow. Another possible use for this output is the engine throttle—to increase and decrease the RPM of the pump shaft. In applications such as these, the flow rate value in this field should be below the low flow rate with a fully open nozzle or the output will never turn on. Another application of this field is to set the value as a maximum flow rate at which a valve should be closed. On fuel delivery trucks, flow valves often activate an internal switch at approximately 18 GPM (68 LPM). The value of this field is unique to each product.

Auxiliary 2 Output – A list box that determines how any digital output that is set to AUX 2 will operate based on the selected product on the Register. There are several features in the Register that can be performed based on the Aux settings to control external components such as pumps, injectors, PTO, Throttle, alarms, and reset pulse.

Options:

- **Off** - Any output set to AUX 2 Calibration Mode Settings will always be off (Not active)
- **On** - Any output set to AUX 2 Calibration Mode Settings will always be on (Active and Sinking to ground)
- **On - During Active Delivery** - Any output set to AUX 2 Calibration Mode Settings will be on (Active and Sinking to ground) when a delivery is active on the Register. The output will be on when a delivery is started and will not turn off until an end of delivery command is given.

- **On - During Run State** - Any output set to AUX 2 Calibration Mode Settings will be on (Active and Sinking to ground) when a delivery is active and not paused. The output will be on when a delivery starts. However, if the delivery is paused by issuing a stop command, the output will turn off until the resume command is given. If the end of delivery command is given, the output will remain off and the delivery will end.
- **On - Flow Rate Monitor** - Any output set to AUX 2 Calibration Mode Settings will be on when a delivery is active. However, it will deactivate if the flow rate meets or exceeds 40 units/time. If the flow rate does not meet or exceed 40 units/time, the output will remain on.
- **On - Reverse Flow** - Any output set to AUX 2 Calibration Mode Settings will be off when a delivery is started and will only turn on when the register detects flow in the negative or reverse direction.
- **Reset Pulse/Delivery Start** - Any output set to AUX 2 Calibration Mode Settings will output a short pulse at the start of a delivery that is used with 3rd-party remote counters that require a reset pulse to reset to 0.0.
- **Toggle Flow Rate** - Any output set to AUX 2 Calibration Mode Settings will turn on once the flow rate of the Register exceeds the set flow rate point in the Auxiliary 1 Flow Rate Toggle field below.
- **Calibrated Scaled Pulse Output** - Any output set to AUX 2 Calibration Mode Settings will output a calibrated pulse output that is scaled according to the Pulse Output Frequency setting in the calibration mode.

Auxiliary 2 Flow Rate Toggle – A numeric text field for programming a flow rate set point, when the Aux 2 is set to Toggle flow rate. Auxiliary 2 remains activated above the set flow rate value, and deactivates when the flow rate falls below the value.

Net Totalizer – A numeric text field that shows the current accumulative net totalizer value of the current selected product on the Register. The Net Totalizer uses a non-resettable totalizer. However, it can be programmed as necessary in the Weight and Measures (Calibration) mode if reprogramming is required. **(Maximum setting - 999999999 units)**

Gross Totalizer – A numeric text field that shows the current accumulative gross totalizer value of the current selected product on the Register. The Gross Totalizer uses a non-resettable totalizer. However, it can be programmed as necessary in the Weight and Measures (Calibration) mode if reprogramming is required. **(Maximum setting - 999999999 units)**

Calibration (3/4)

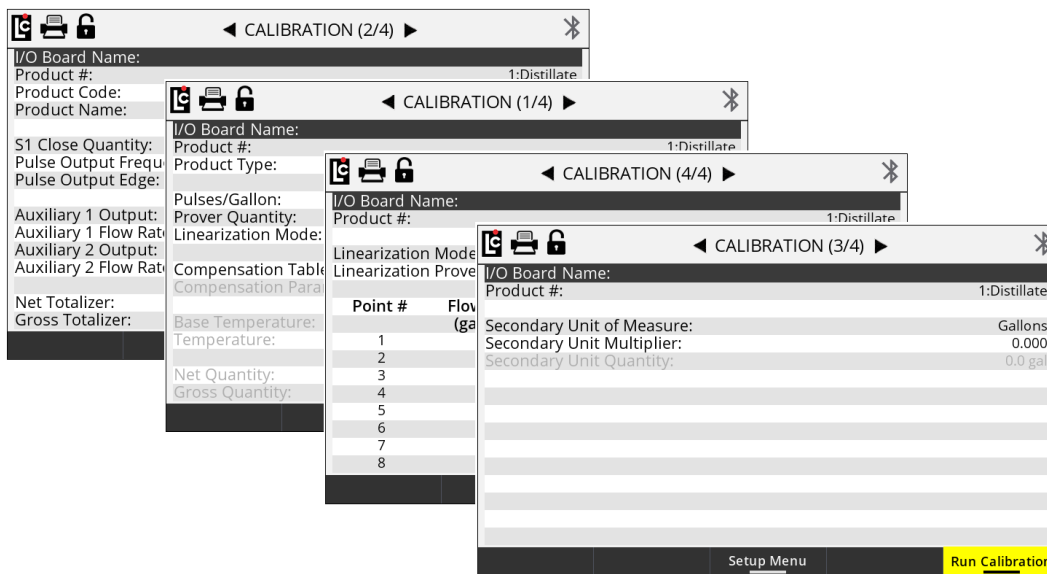

Product # – A list box containing 16 products that are available for setup and calibration of the Register.

Options: Products 1-16 are available for setup. Only setup and calibrate products that are to be used by the Register.

Secondary Unit of Measure – A list box that can be set up to be the unit of measure label when printing or displaying a secondary unit of measure. See the Secondary Unit Multiplier below for setting descriptions.

Options:

- Gallon
- Barrel
- Cubic Meter
- Decalitre
- Litre
- LB (Pound)
- KG (Kilogram)

- Other

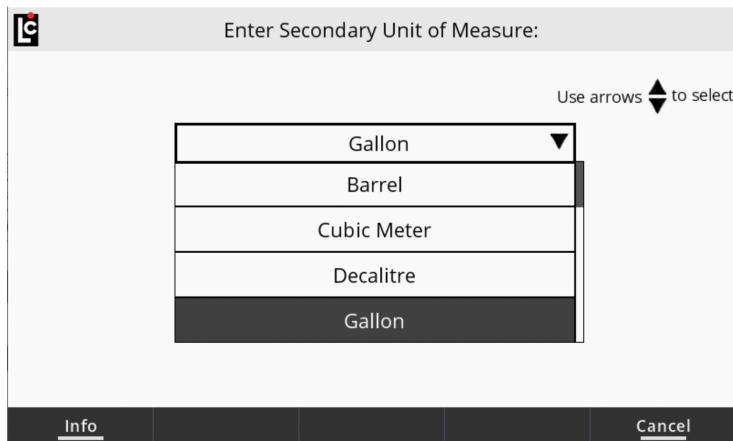

Secondary Unit Multiplier – A numeric text field for applying a multiplying factor to the primary unit of measure in order to obtain a secondary unit of measure. An example of this would be a primary unit of measure in Gallons together with a multiplier of 3.78 that is entered to create a secondary unit of measure in Litres. **(Maximum setting is 9999.999)**

Secondary Unit Quantity – A read-only field that will display the secondary unit of measure if programmed for use.

Calibration (4/4)

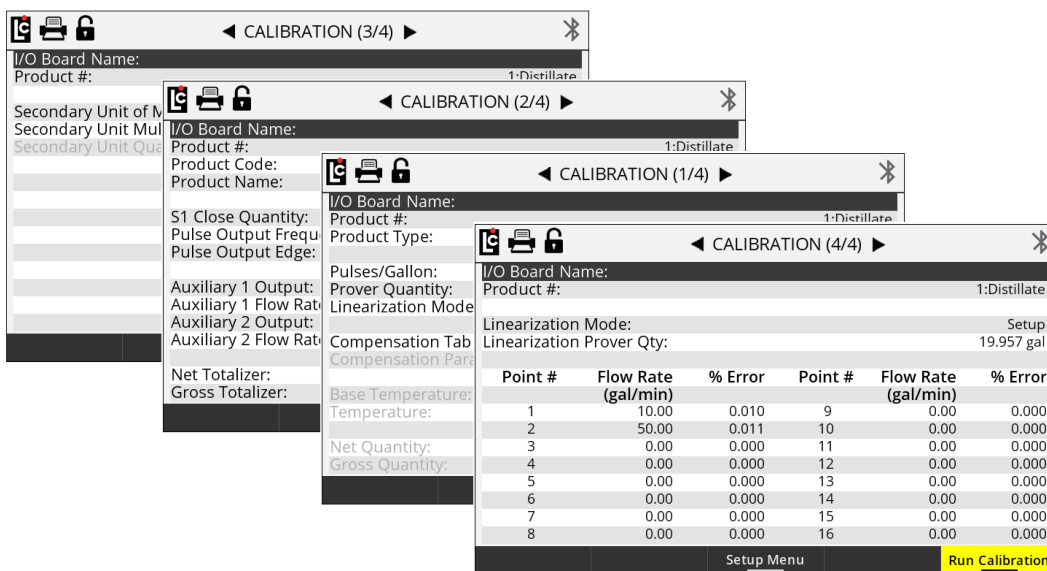

Product # – A list box containing the 16 products that are available for setting up and calibrating the Register.

NOTE:

- Products 1-16 are available for setup. Only setup and calibrate products that are to be used by the Register.

The Register provides two means of calibration, single-point [Calibration screen (1/4)] or multi-point calibration [Calibration screen (4/4)].

A “point” corresponds to a particular flow rate along the meter linearity curve. Single-point calibration adjusts one point along the linearity curve to zero percent error—typically at a flow rate representative of a normal delivery. Since meter linearity varies at different flow rates, and every meter behaves differently, the more points of calibration will generally result in more accurate fluid measurement.

Multi-point calibration zeroes the percent error at multiple flow rates (between the rated lowest flow rate and highest flow rate of the meter) in order to zero-out the linearity curve across the rated flow range.

To multi-point calibrate the meter using the Register (Calibration screen 4/4), first select point #1 and enter the lowest flow rate measured. Then, enter the % error measured at that flow rate. Repeat this for points 2 through the highest number of points measured (up to 16 points available).

Linearization Mode – A list box for applying a multi-point calibration. Setting this field to **Applied** will activate multi-point calibration—if all parameters are met for using multi-point calibration.

Linearization Prover Qty – A numeric only text field for performing a multi-point calibration on the currently selected product on the Register. This field is used during multi-point calibration to enter the known prover quantity of a volumetric proving device or master meter. Following a multi-point calibration run, entering a value into this field will automatically prompt the user to select a point to apply the run to, followed by a prompt to enter the flow rate that was used during the multi-point calibration run. This action will store the point and flow rate, then calculate the percent error to be applied to the selected point.

Point – A list box for selecting the calibration point for the multi-point calibration. The Register is able to perform a multi-point calibration on as many as 16 separate points.

Options:

- Linearization Points 1-16 are available for setup.

Flow Rate – A numeric text field for entering the actual flow rate at which a multi-point calibration run was made.

% Error – A numeric field that is used when the Register calculates the percent error for a multi-point calibration point. The percent error field can also be manually entered for meter systems that have a factory supplied accuracy curve.

Security

Security settings are for setting up and configuring the user level security, and also access to the **Clear All** process, software upgrades, Audit Trails and Reset Register Fields feature. Setting the security level to **Locked** will prevent an operator from accessing fields that the owner may want to restrict.

SECURITY	
Date Format:	MM/DD/YY
Current Date:	11/03/16
Calibration #:	2
User Key:	
User Security:	Locked
Menu Access Protection:	None
Serial ID:	DC7A179679
Reset Register Fields:	No
Factory Key:	
<div style="display: flex; justify-content: space-around;"> Setup Menu Software Update Audit Trail </div>	

Date Format – A list box for setting the display and print format for the Register date.

Options:

- MM/DD/YY - Month/Day/Year
- DD/MM/YY - Day/ Month/Year

Current Date – A fixed data entry field for setting the internal calendar of the Register–based on the date format field option. The Register will update the calendar automatically according to this setting, and the date can be displayed on screen, printed on the ticket, and recorded in each transaction record.

Calibration # – A read-only field that will display the number of times the Register been placed into the calibration mode.

Serial ID – A read-only text field that will display the serial number of the main board inside the Register.

User Key – A text field for entering a unique key code for unlocking access to specific menus and features in the Register. This user defined key should be set and saved by an owner or maintenance manager for secure access to these menus and features. Contact Liquid Controls customer support if you misplace or forget your user key. The user key is retrievable through the factory-calibration mode only.

User Security – A list box for toggling the security level between the locked and unlocked mode.

Options:

- **Locked** - When set to locked, access to certain screens and menu options is blocked without entering the user key.
- **Unlocked** - When unlocked, access to all menus is available–while menu options may still be unavailable based on the security current mode of the Register.

Menu Access Protection – A list box to configure which menus will require the entry of the user key to access different menus.

Options:

- **Main Menu** - Setting this field to **Main Menu** will require the user to enter a user key to access any of the main menu screens outside of the delivery screens.
- **Setup Menu** - Setting this field to **Setup Menu** will permit the user to access the main menu. However, it will restrict access to the **Setup** menu and require a user key for access.
- **None** - No menu level restriction is applied. However, access to screen options may still be unavailable based on the current security mode of the Register.

Reset Register Fields – A list box that permits access to the **Clear All** and **Rebuild** functions of the Register when in the Weights and Measures calibration mode. This process should only be performed by a trained technician or Liquid Controls factory representative.

Options:

- **Clear All** - Performing a **Clear All** will remove all current settings and set all parameters back to factory default (except Time and Date). This process should only be performed by a trained technician or Liquid Controls factory representative.
- **Rebuild** - Performing a rebuild will attempt to repair an Register, in case an area of the Register memory become corrupt. This process should only be performed by a trained technician or Liquid Controls factory representative.
- **No** - Make no selection and return to the **Security Mode** screen (or press **Cancel**)

Factory Key – Consult Liquid Controls for factory Key information and access.

I/O Setup

I/O setup screen are used to setup and configure the various available inputs and outputs of the Register, and also activate and deactivate services such as printing, LCP communication, dP, Density and other sensing equipment.

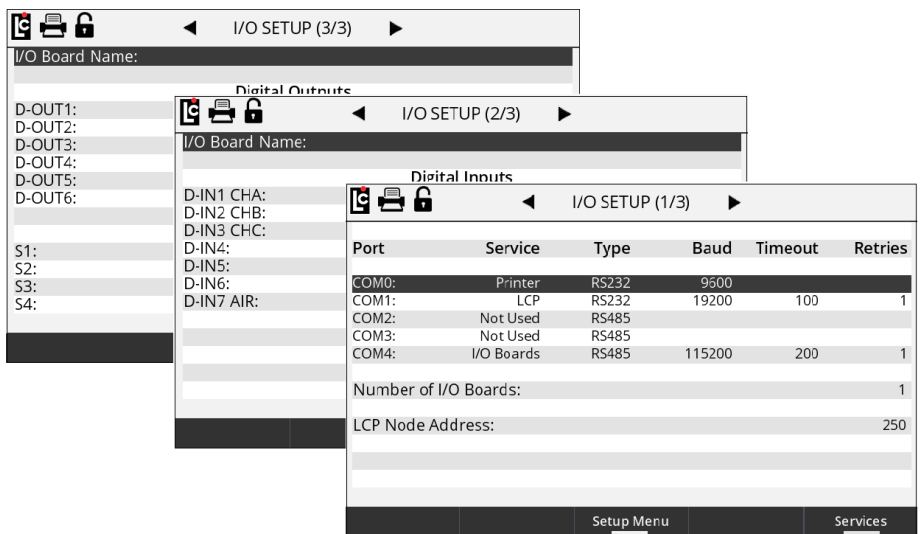

I/O Setup (1/4)

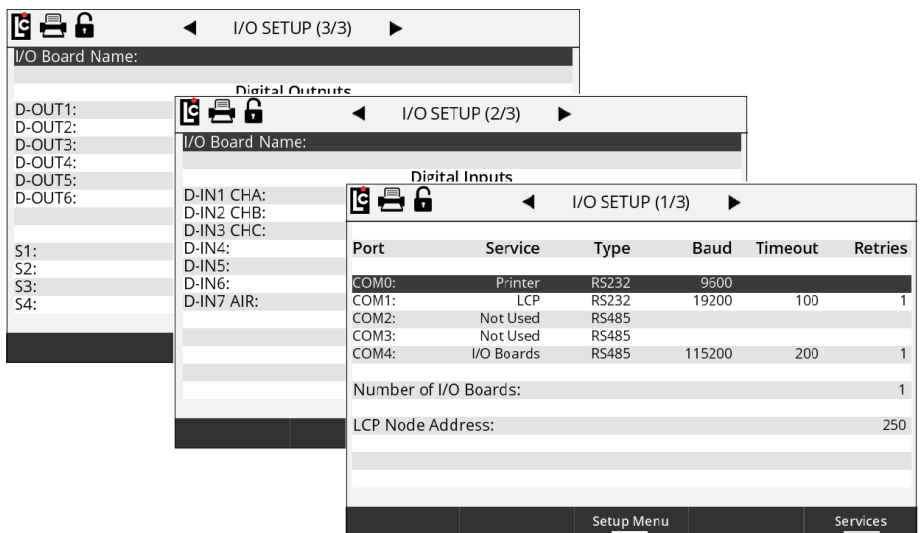

COM0 – COM4 – The Register has five serial ports. When one of the ports is selected, prompts for the Service, Type, Baud, Timeout, and Retries are shown. **COM4** must be used with the I/O Boards service.

Service – A list box that permits the user to select between the services that have been enabled on the **Services** screen. **Not Used** can be selected to disable the use of the port.

Type – A list box permits the user to select between the types of serial communication for the serial port.

Options:

- RS232
- RS485

Baud – A list box that permits the user to select the baud rate for the serial port.

Options:

- 2400
- 4800
- 9600 – This is the standard baud rate used for the Printer service.
- 19200
- 57600
- 115200 – The I/O Boards service must use this baud rate.

Timeout – A numeric text field that shows the amount of time, in milliseconds, the Register will wait for a response, once a serial signal is sent out the port. This field is only used for the LCP and MASTERLOADx.iQ Network services.

Retries – After a serial signal has been sent out the port, if a response isn't seen within the Timeout, this is the number of attempts the Register will attempt to retry sending the serial signal. This field is only used for the LCP and LCR.iQ Network services.

Number of I/O Boards – The number of I/O boards within the Register. The current limit is 1.

LCP Node Address – A numeric text field that shows the node address of the Register when communicating with a 3rd party device via the LCP service. (**Minimum setting – 1, Maximum setting - 250**)

Allow Pump & Print with LCP Host – A list box permits the user to select how the LCP service will behave.

Options:

- **No** – When the register receives an LCP message, the **Start** key will be disabled for 60 seconds. If the user wants to begin a delivery, it must be done through the 3rd-party device.
- **Yes** – The **Start** key on the register will not be disabled during LCP communication. This allows the user to always be able to begin a delivery from the register screen.

I/O Setup (2/4)

To utilize this functionality, first navigate to the Main Menu, then Setup Menu, then I/O Setup and I/O Setup 2/4.

To configure LCP over the Ethernet, select LCP Service on either ETH0 or ETH1. Then configure appropriate Network settings as follows:

1. Set the **Network Mode** to **Station Mode**.
2. Or, set the **Network Mode** to **Station Mode with Static IP**, and then select **Network IP Address**.
3. Tap **Apply Network** to apply these changes.

NOTE: Only one of the network interfaces either Wi-Fi or Ethernet can be enabled at time.

Details for the other settings in this screen are given below.

The screenshot shows the 'I/O SETUP (2/4)' screen with the following settings:

Bluetooth	Service	Timeout	Retries	
BT0:	Not Used			
Wi-Fi	Service	Port	Timeout	Retries
WF0:	Not Used			
WF1:	LCP		500	1
Ethernet	Service	Port	Timeout	Retries
ETH0:	Not Used			
ETH1:	LCP		500	1
Bluetooth Mode:		Printer Mode		
Network Mode:		Station Mode		
Network Name:		LCRIQ-f8-dc-7a-17-96-27		
Network IP Address:		0.0.0.0		

At the bottom of the screen, there are three buttons: Setup Menu, Wireless Conn., and Apply Network.

BT0 – The register has one Bluetooth port. Choosing this option will display prompts for the **Service**, **Timeout**, and **Retries**.

Service – A list box that permits the user to select between the services that have been enabled on the Services screen that can be used over Bluetooth.

Options:

- **Not Used** – This disables the use of Bluetooth.
- **LCP** – LCP communication over Bluetooth.
- **Printer** – To be used with a Bluetooth printer.

Timeout – A numeric text field that shows the amount of time, in milliseconds, the register will wait for a response, once a serial signal is sent out the port. This field is only used for the LCP service.

Retries – After a serial signal has been sent out the port, if a response isn't seen within the **Timeout**, this is the number of attempts the register will attempt to retry sending the serial signal. This field is only used for the LCP service.

WF0 & WF1 – The register can establish two wi-fi connections. Choosing this option will display prompts for the **Service**, **Timeout**, and **Retries**.

Wi-Fi Mode – A list box permits the user to select which Wi-Fi Mode to use.

Options:

- **Wi-Fi Direct** – Does not require a wireless access point, allowing two devices to establish a direct Wi-Fi connection without requiring a wireless router.
- **Wi-Fi Stationary** – Requires a wireless access point to act as a hub for Wi-Fi communication.

SSID Name – An alpha-numeric text field that shows the service set identifier for the register. Other devices will use this name to identify the register and establish a connection. The default value begins with "LCR.iQ", which is followed by a unique identifier.

SSID Password – An alpha-numeric text field that shows the password for wireless communication with the Register. Other devices will use this password to establish a connection.

Wi-Fi Direct IP Address – The IP address of the register when in Wi-Fi Direct Mode.

Apply Wi-Fi – The user must press **Apply Wi-Fi** for any changes to the **Wi-Fi Mode**, **SSID Name**, **SSID Password**, or **Wi-Fi Direct IP Address** to take effect.

I/O Setup (3/4)

- Digital Inputs 1-7

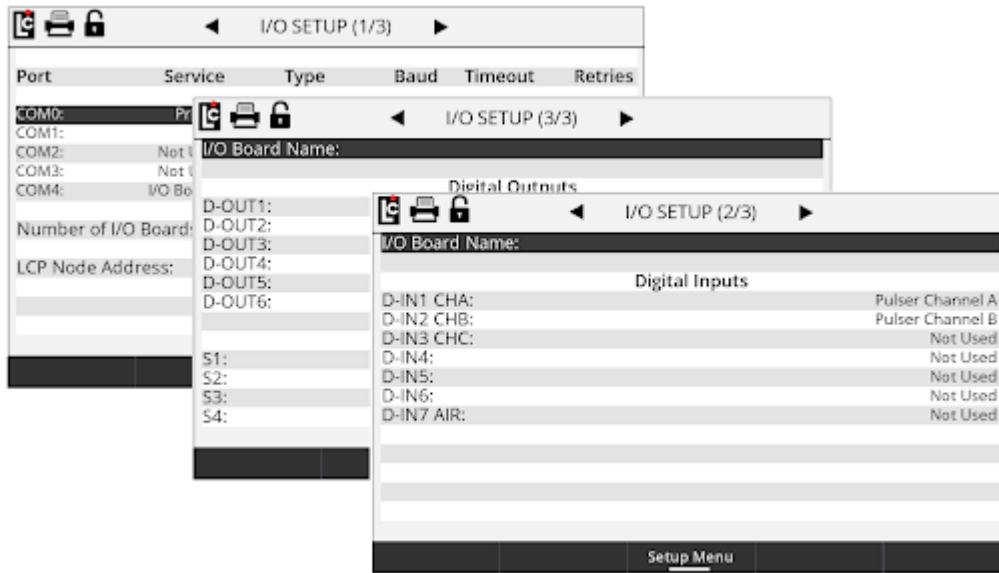

I/O Setup (4/4)

- Digital Outputs 1-6 and Solenoid Outputs S1-S4

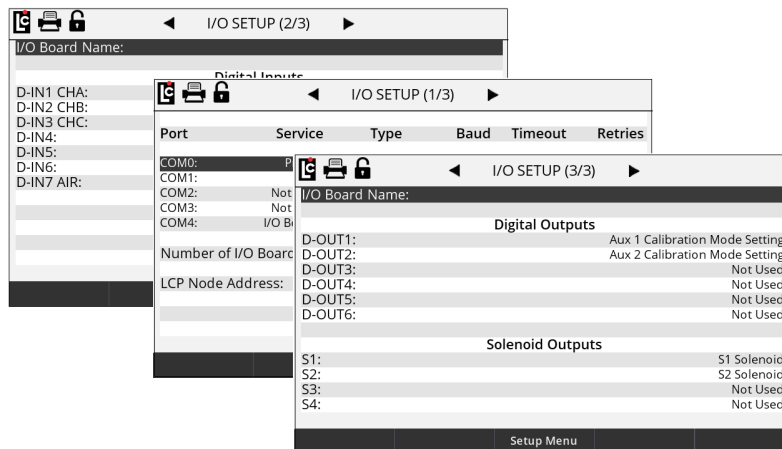

Customize Home Screen

The Custom Home Screen menu permits the user to setup and configure various parameters that appear on the home screen. In these screens, the user can select from a series of default profiles that are common to an industry, or create a custom arrangement from the available drop-down selection options for each line.



Customize Home Screen can be used to configure up to 12 parameters inside one or two data columns displayed on the idle and active delivery screens.

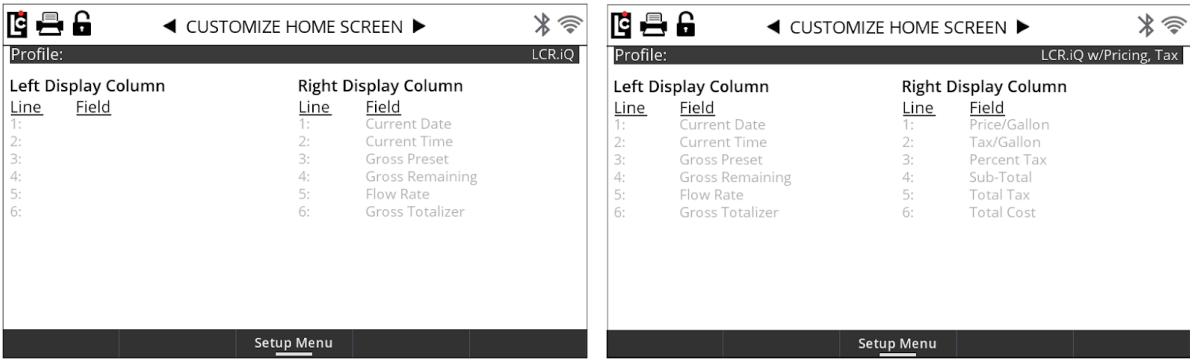

The following preconfigured display profiles are available on the Register:

Preconfigured LPG Profiles are basic screen profiles that are tailored to propane industry standards and available options.

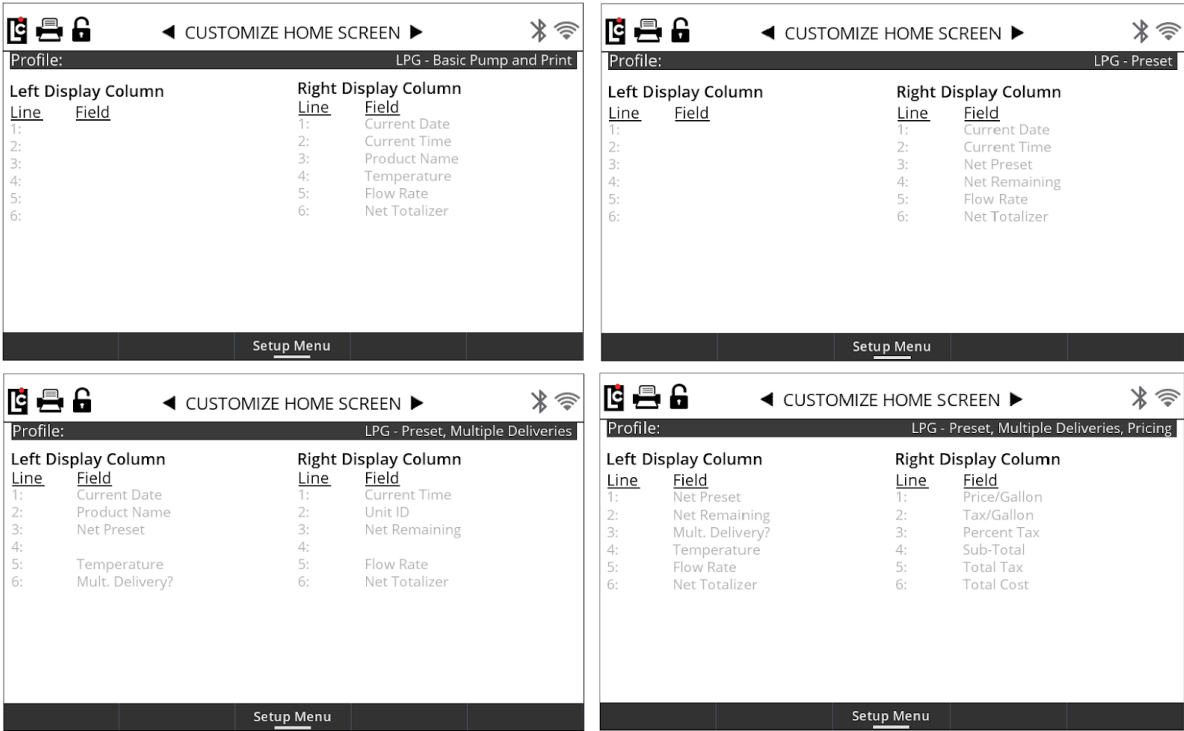

Preconfigured Refined Profiles are basic screen profiles that are tailored to aviation refined fuel industry standards and available options.

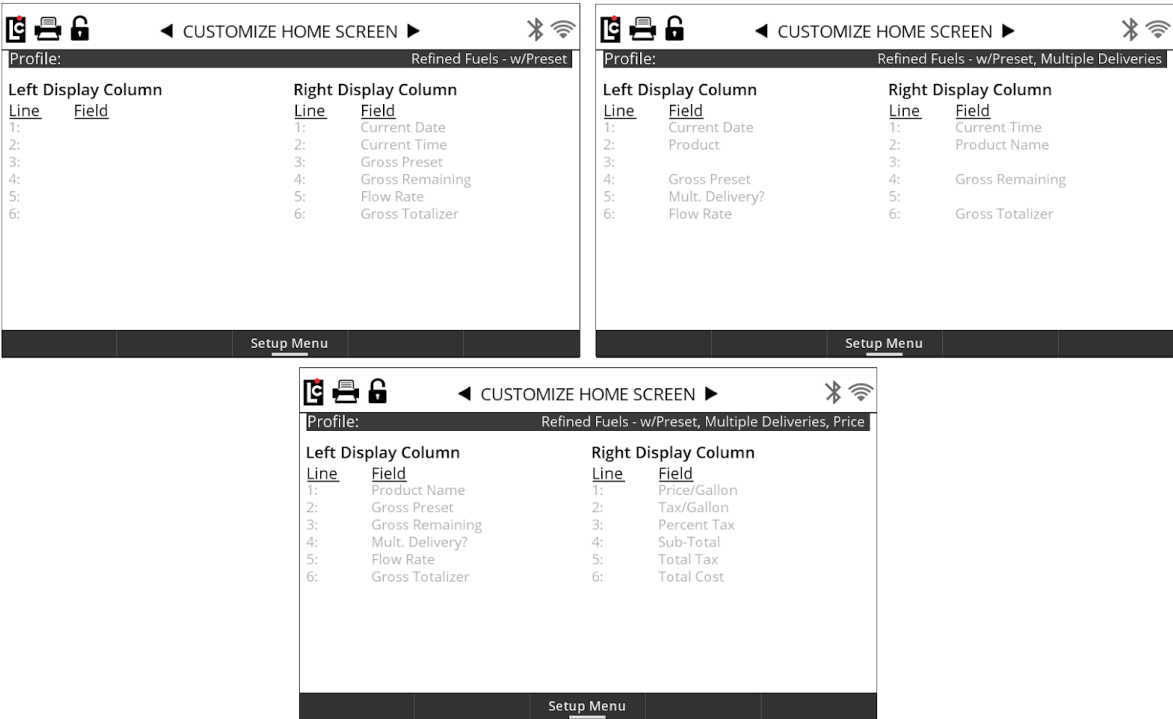

Preconfigured Aviation Profiles are basic screen profiles that are tailored to aviation industry standards and available options.

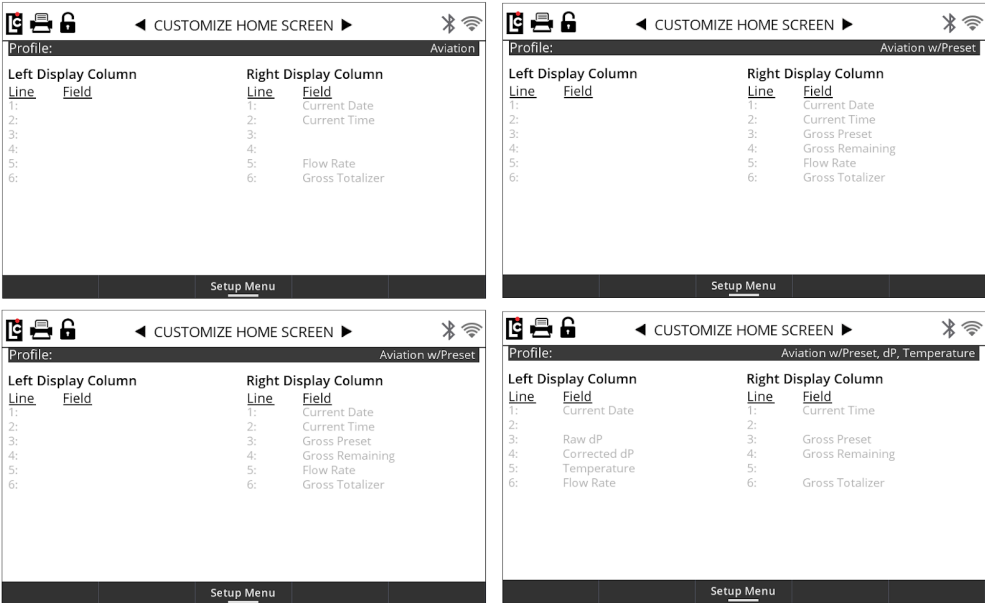

Custom Home Screen design can be done by selecting the **Custom** profile options. Use the navigation keys to scroll the cursor to the column (Left or Right) and field (1-6) then press **OK** to view the available list of fields that can be displayed. Once a selection is made, pressing the **OK** button again will confirm the selection. That field will now appear in the selected column on the home screens.

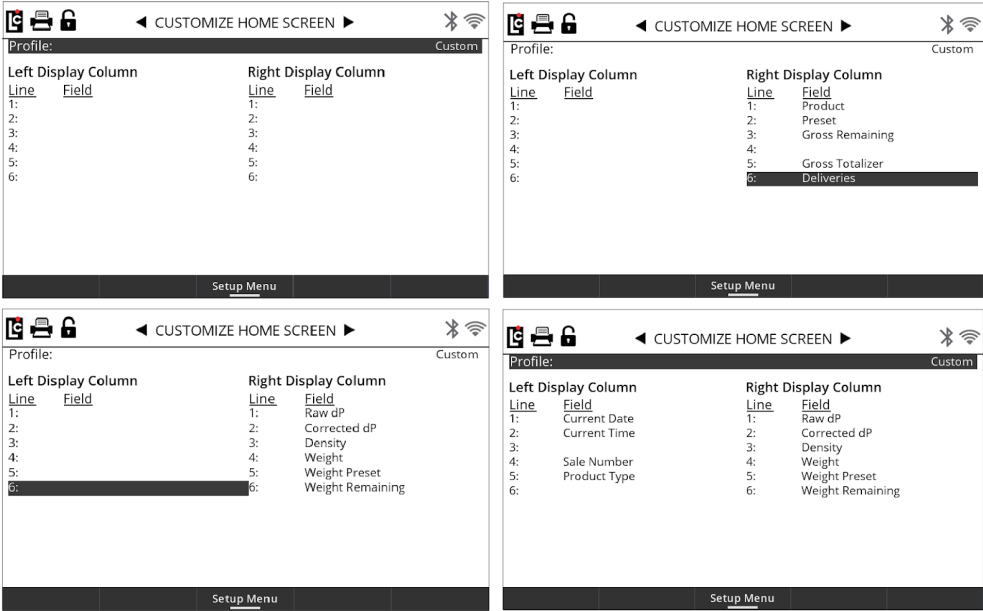

Configure Delivery Setup

This setup configures the delivery options available when the setup delivery function key is displayed. The Register has several preconfigured delivery setup options that correspond to the specific industries. Or, a custom configuration can be setup using the custom option. There are two basic Register screens as well as pre-configured screens for common markets such as **LPG**, **Refined Fuel** and **Aviation**. There is a direct correspondence between the profile selected in the **Customize Home Screen** menus and the **Configure Delivery Setup** menus. If you make a profile selection in **Customize Home Screen**, the same profile will be selected in the **Configure Delivery Setup**.

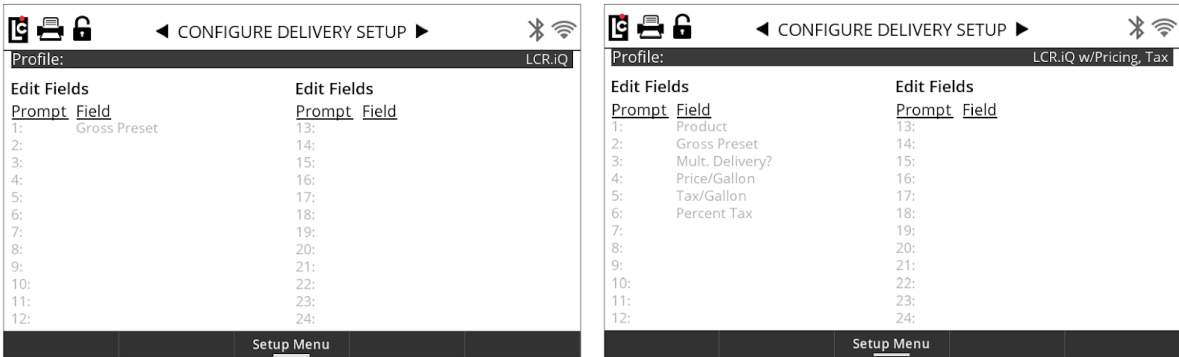

Preconfigured LPG Profiles are basic screen profiles that are tailored to propane industry standards and available options.

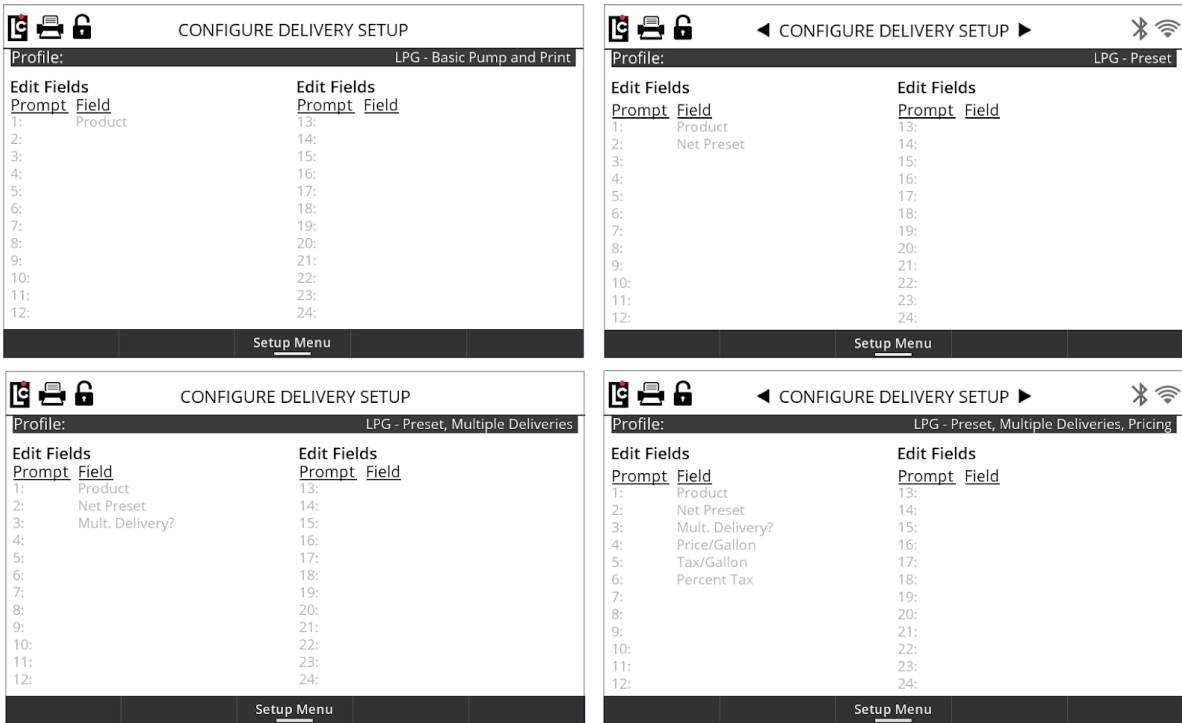

Preconfigured Refined Profiles are basic screen profiles that are tailored to refined fuel industry standards and available options.

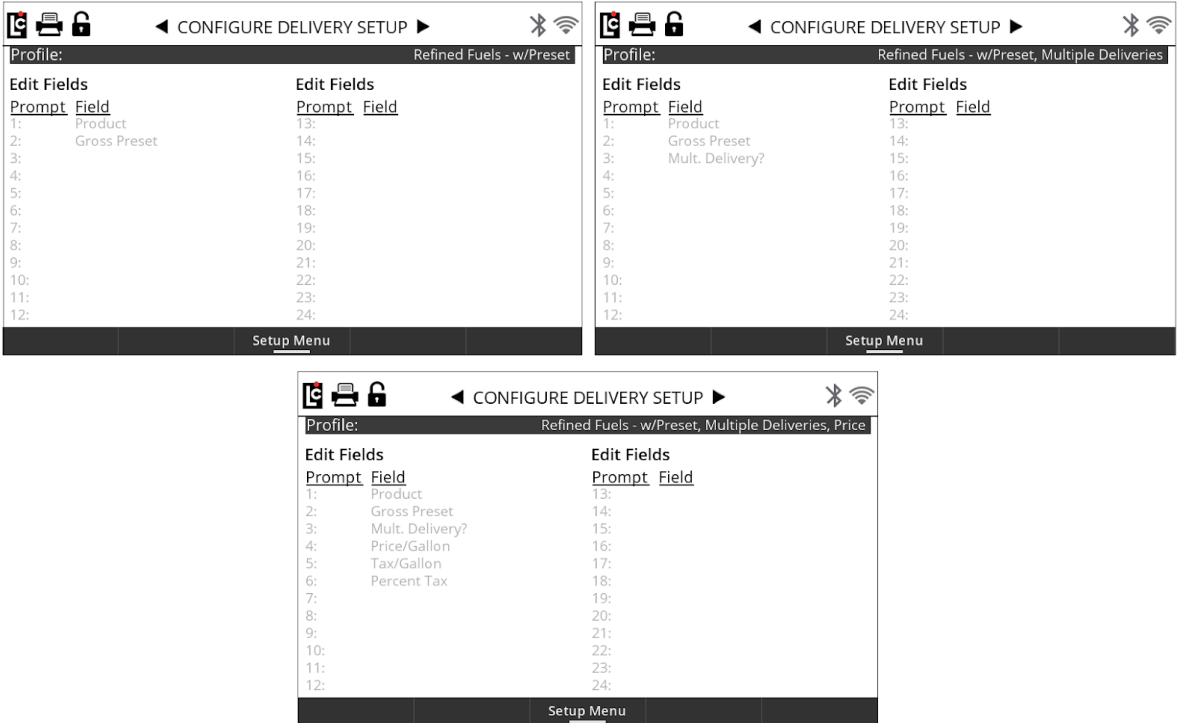

Preconfigured Aviation Profiles are basic screen profiles that are tailored to aviation industry standards and available options.

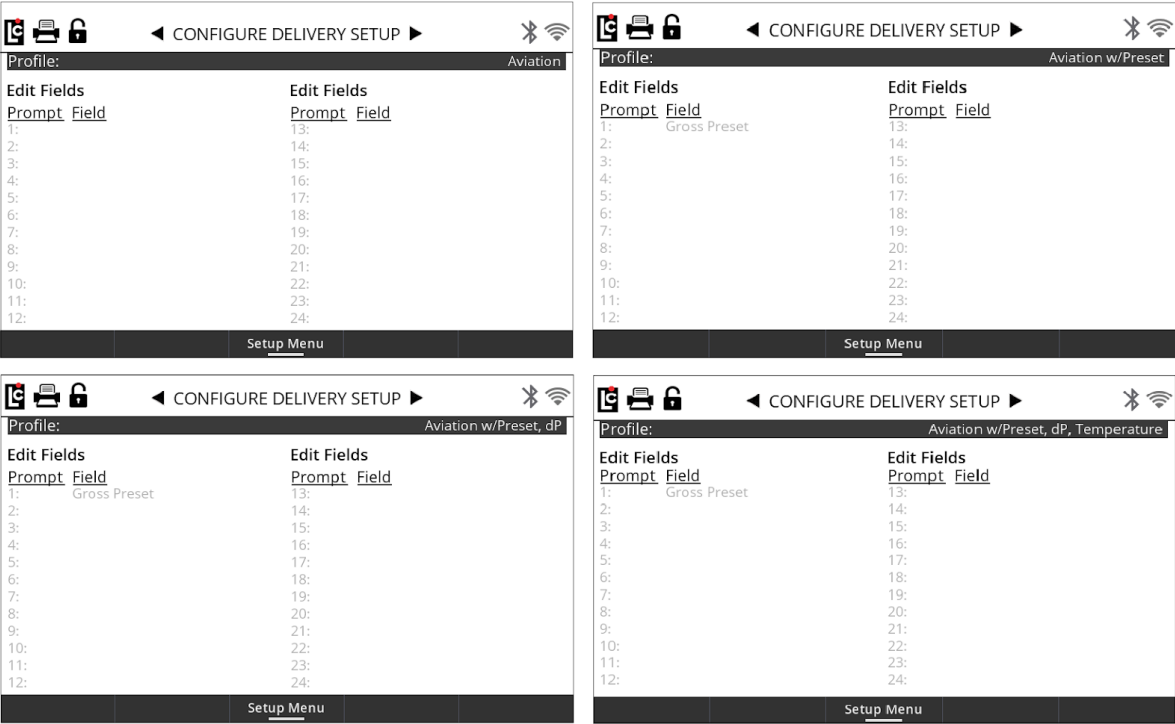

Customizing the Home Screen can be done by selecting Custom profile options:

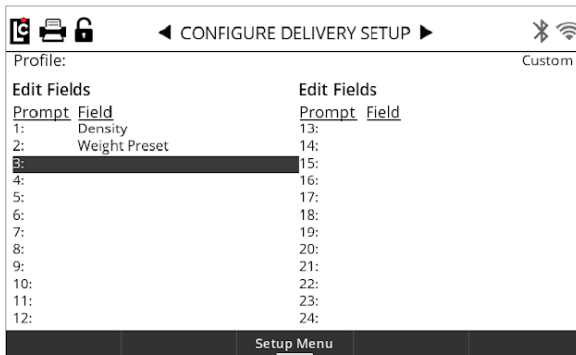
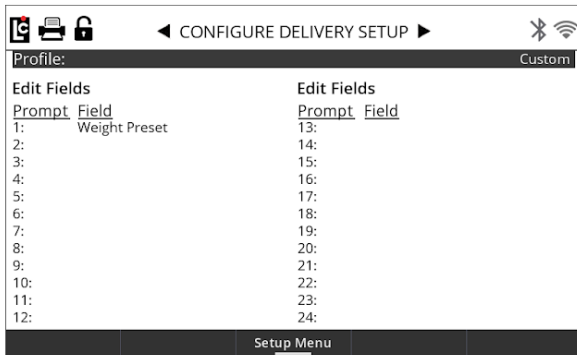
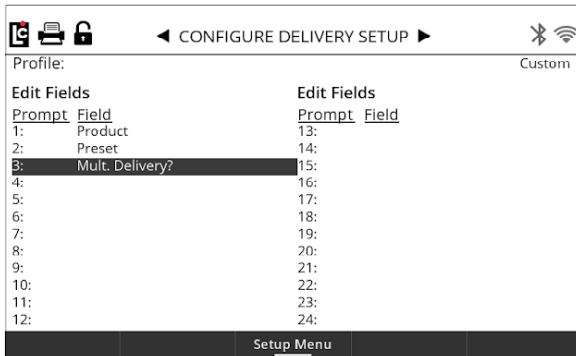
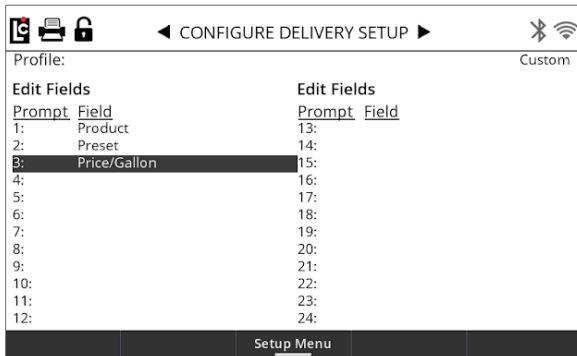
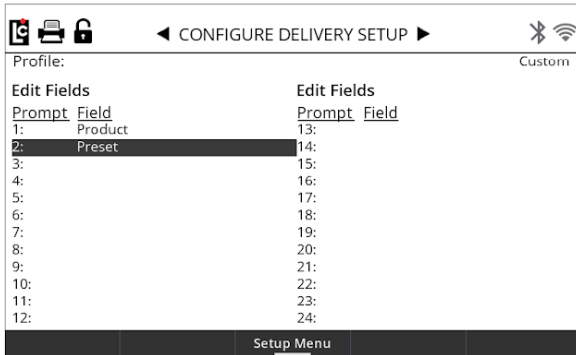
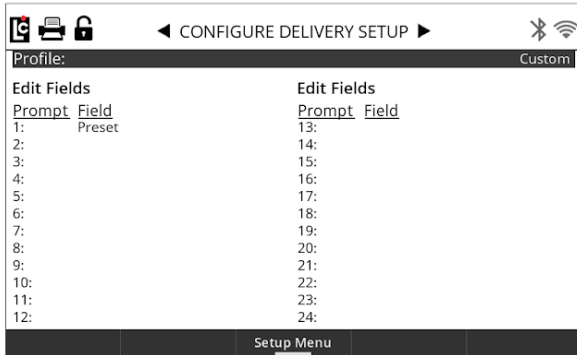
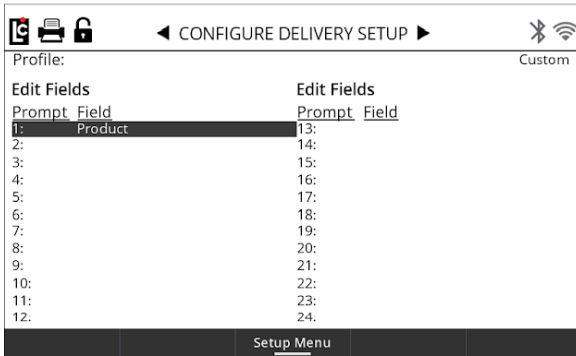
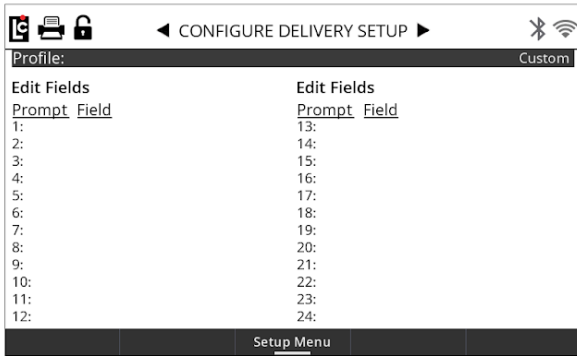

Operating the Register

This chapter covers all of the operations that you can perform with the Register:

- [Performing a basic delivery](#) ^[109]
- [Performing a preset delivery - Preset Key](#) ^[110]
- [Using the Info button](#) ^[110]
- [Performing a preset delivery - Delivery Setup](#) ^[111]
- [Using the hose reset feature](#) ^[115]
- [Single-point Calibration](#) ^[116]
- [Multi-point Calibration](#) ^[117]
- [Setting the S1 Close time](#) ^[120]
- [Setting up delivery ticket options](#) ^[121]
- [Print the previous ticket](#) ^[121]
- [Upgrading the Firmware by USB](#) ^[122]
- [Perform a Clear All Procedure](#) ^[125]
- [Print a transaction](#) ^[126]
- [Setup custom profiles](#) ^[126]
- [Print a diagnostic ticket](#) ^[127]

Performing a basic delivery

Simple and easy. That was the goal when designing the operation of the Register. Making a delivery with the Register can be as simple and easy as pressing the yellow **Start** key.

When you're ready to begin a basic delivery, press the **Start** key. The register will start the reset process by completing a display test, then will reset to zero. At this time if the Register is connected to a flow control valve, the register will send a signal to open the valve and possibly signal a pump to start. With the pump on, fuel will begin to flow through the meter and register on the display. The main delivery screen of the Register will always default to the active fueling screen with large, high resolution digits.

While a delivery is active, it is possible to view detailed delivery information by pressing the **Show Details** button. The detailed information displayed is configurable depending on the

profile which can be configured on any register. A separate how to instruction on setting up a profile is available.

To return to the default fueling screen, simply press the **Full Screen** button and the default delivery screen will now be displayed.

At any time during the delivery, pressing the **Stop** key will pause the delivery by sending a signal to the flow control valve (if installed) to close. You'll also see that the display now has a **Resume** key.

Pressing the **Resume** key will resume the delivery after it is stopped by sending a signal to the flow control valve to open.

To end a delivery, pressing the **End** or **End and Print** button will complete the transaction. If a printer is connected, this will also print the delivery ticket.

Once the delivery is complete, the display will return to the Idle home screen and the Register is ready for the next delivery.

Performing a preset delivery - Preset Key

Presetting with the Register is simple. There are a few different ways to enter a preset depending on how the register is configured. The most basic way if presets are configured for use, is when presetting is the only delivery setup option. In this case the Register will display a preset function key on the main delivery idle screen. If a preset is desired, simply press the preset function key and a prompt to enter the preset amount will appear on the screen. Use the alphanumeric keypad to type in the preset amount, then press **OK** to accept the amount entered. Start the delivery as normal and your system will stop at the entered preset amount.

Using the Info button

The **Info** button is a helpful tool for the technician or user that does not have access to the setup and operation manual when setting up and programming the register. Like the manual, the **Info** button will give the user valuable information about the field and available parameters.

Follow these steps:

1. To access information using the Info button, navigate to any available field and press OK to access the field data.
2. Once in the field data, the screen will display a function key labeled Info.
3. Press the Info button and the screen will now display the info details.

List Boxes will display the default setting, current setting, field description and a list of options that may also include detailed description information. Text Boxes will display the default value, current value, minimum and maximum number of characters for the field or minimum and maximum value for the field, accepted data type and a field description.

4. While in an info screen, text data can be entered, however the user must exit the info screen to make a list box selection.
5. To exit an info screen, press the **Close Info** function key.

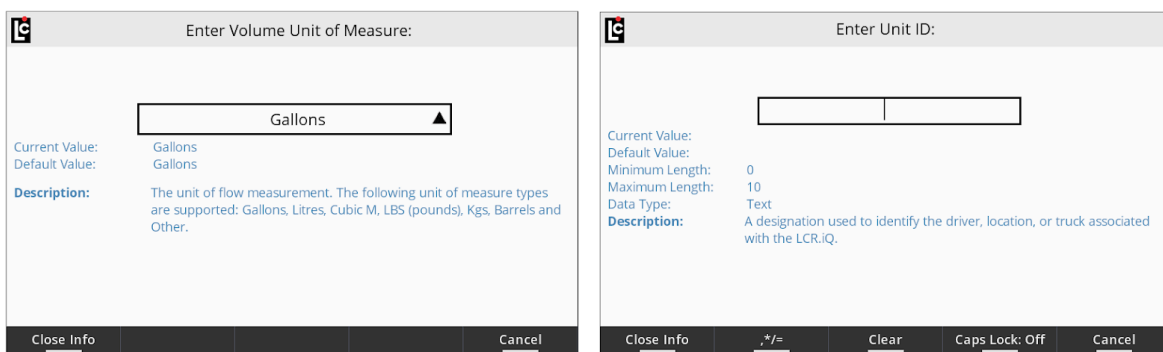

Performing a preset delivery - Delivery Setup

If you have configured delivery setup prompts including the preset field, press the Setup Delivery function key and follow the on screen prompts until you see Enter Preset. After entering the preset, press OK to accept the amount entered. Continue with any remaining setup delivery prompts, then start the delivery as normal and your system will stop at the entered preset amount.

Add to a Preset

If you have started a preset delivery and you need to add to the amount, or if you are using the multiple preset type option, it is possible to add to or append the preset amount. Simply press the **Stop** key, then press the **Preset** key and a prompt will be shown on the screen to enter a

new preset volume. Once the new volume is entered, press **OK** to accept the change and then press the **Resume** button to continue fueling.

Selecting a Preset Type

When selecting a preset type, it is important to know how the register will be used in the preset process. There are 3 options when selecting a preset type: **Clear**, **Retain**, and **Multiple**. The best way to describe each is by example.

Clear a Preset

If you are currently using a mechanical preset, the clear option will best match this functionality. A clear preset allows the user to set up a preset amount for a specific delivery. Using the Register keypad, enter the desired preset value by pressing the preset key or if using the delivery setup mode, enter a preset when prompted. Once the preset is entered and the delivery is started, the Register will deliver the set preset amount and complete the delivery once the amount is reached. With electronic registration this means that the end of delivery command will be generated and if applicable, the completed delivery ticket will be generated. This action will set the preset field back to zero (Clear) so the register is ready for the next delivery. If the next delivery also requires a preset, the user will need to enter a new preset amount following the same steps.

Retain a Preset

If you are planning to use the Register for batching, the retain preset is the best option for this process. Retain preset allows the user to set a preset amount on the register and retain that amount from delivery to delivery, each time issuing an end of delivery command and resetting the delivery amount back to zero but retaining the preset amount. The preset amount will be retained until an operator sets a new preset amount or sets the preset back to zero for no preset.

Multiple Presets

For applications in which you have an initial preset volume, but the final preset volume has not been determined, it is best to use the multiple preset option. Multiple preset allows the user to set a preset amount. However, once the preset is reached, the delivery is paused, not completed. This allows the user to either add more fuel on top of the preset amount or set another preset amount for the remaining amount. This process can be repeated over again until such time that a final amount is determined. Once the final amount is determined, the user issues the end of delivery command by pressing the **End/Print** key terminating the delivery. At

this time, the preset amount is set back to zero and the user must set a new preset amount, if desired, for the next delivery.

Split screen setup

Optionally, you can split the Idle/Active Delivery screens by choosing to display a field in addition to the Delivery Volume (Net/Gross).

REGISTER (2/4)	
Sale Number:	23
Ticket Number:	45
No-Flow Timer:	180 sec
Gross Presets Allowed?	Yes
Net Presets Allowed?	Yes
Weight Presets Allowed?	Yes
Price Presets Allowed?	Yes
Price Presets Target:	At Least the Entered Price
Preset Required?	Yes
Preset Type:	Retain
Activate Hose Reset Option?	Yes
Additional Split Screen Data Displayed:	Total Cost

Setup Menu

The secondary field selection is currently limited to **Flow Rate** and **Total Cost** (of sale).

Enter Additional Split Screen Data Displayed:

Use arrows to select

Total Cost ▼

None

Flow Rate

Total Cost

Info Cancel

Select **Total Cost** to display the Idle screen and the Delivery screens split-screen mode, as shown below. Both the **Total Sale** and **Gallons** will appear in large digits.

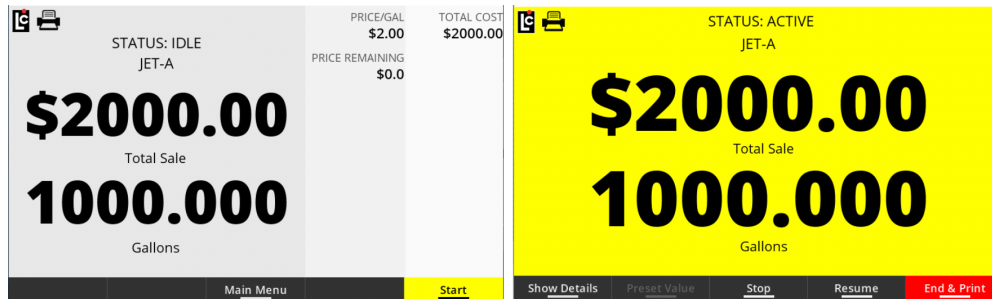

Select **Flow Rate** to display the Idle screen and the Delivery screens in split-screen mode, as shown below. Both the **Flow Rate** and **Gallons** will appear in large digits.

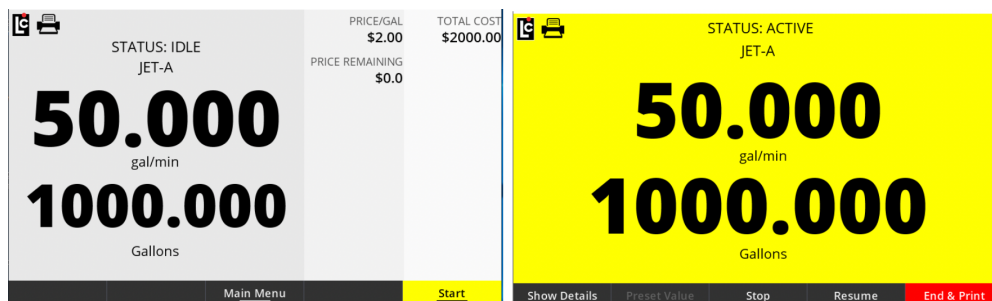

Setting Product Price and Taxes

There are two ways to apply pricing to a delivery. The first method is to use the original three pricing fields to provide the untaxed price/unit along with an optional tax/unit—and/or a percent tax. New to the iQ Register is an alternate way of specifying delivery pricing which is to use the **Price Including Taxes** field on the [Delivery Details \(1/4\)](#) ³⁸ screen.

The **Price Including Taxes** field provides a way to accurately achieve a price preset. Using one pricing field that includes all taxes allows the register to always stop accurately at the desired price preset.

When any of the original three pricing fields are set, the **Price Including Taxes** field is set to 0.0000. If this value is set, all of the original three pricing fields are also set to 0.0000.

Follow these steps to set the value in the **Price Including Taxes** field:

1. Navigate to the Delivery Details (1/4) screen, by pressing the **F3/Main Menu** key on the Home screen, and then select the **Delivery Details** option on the Main menu.
2. Select the **Price Including Taxes** field and press the **OK** key.
3. Enter a value in the range -9,999.99 through 9,999.99, then press the **OK** key.

NOTE: The original three pricing fields will be set to 0.0000 when the “Price Including Taxes” field is set.

DELIVERY DETAILS (1/4)	
Product #:	1:Gasoline
Product Code:	11111
Product Name:	Gas
Preset Type:	Clear
Net Preset:	0.0 gal
Gross Preset:	0.0 gal
Weight Preset:	0.0 lb
Price Preset:	\$0.00
Price Including Taxes/Gallon:	\$0.00
Price/Gallon:	\$0.00
Tax/Gallon:	\$0.00
Percent Tax:	0.00%
Multiple Deliveries?	No
No-Flow Timer:	180 sec

Home Main Menu End Shift **Start**

Using the hose reset feature

The hose reset feature is a Weights and Measures requirement that allows the user a one-time reset of the register back to zero after a delivery is started in order to charge the hose with system pressure. This assumes that the amount to charge the hose is within the hose reset features limits. The reason this feature is permitted, is that following a preset delivery, the meters preset valve (on the outlet of the meter) closes once the preset amount is reached, yet the fueling nozzle at the end of the hose is still open. This causes a small void in the packing of the hose because of the loss of system pressure.

To use this feature, start a delivery on the Register and engage the pump (apply system pressure)—while leaving the nozzle closed. If the meter jumps up a few tenth of a unit, this is because there was a void in the hose that has now been filled by adding the pump pressure. If the amount is less than 1 gallon (or 4 Liters), the user is able to reset the register back to zero

by pressing the **Stop** key, followed by the **Hose Reset** key. At this time, the register will be reading zero again and by pressing the **Resume** key, the user can continue with normal delivery functions.

Single-point Calibration

Single-point calibration of the Register is designed to be quick and easy. Calibration of the Register should be performed by a qualified Weights and Measures authorized or factory trained technician. Typical calibrations are done using a volumetric prover, master meter or inline SVP (Small Volume Prover). Ensure that all equipment is properly connected and lines fully charged (pressurized) between the meter and proving device.

To begin the calibration process, you must first put the Register into the calibration mode by removing any existing seal wire and loosening the calibration bolt on the side of the register housing approximately 5-6 turns. If a ticket printer is connected to the Register, make sure a ticket is in place and the printer is ready. If connected, the register will print a calibration ticket showing the current calibration information of the register. If no ticket printer is connected or the calibration ticket is not desired, press the **Abort** key to skip the print process.

Once in the calibration mode, select the calibration option from the main menu to access the calibration screens. If this is the first calibration for the register or if the calibration factor (Pulse/Unit) has not been set for the meter that the register is connected to, it is recommended to set a starting factor. This will save time and additional calibration runs as the register adjusts the meters accuracy closer to zero error. See the recommended starting calibration factor chart in the appendix of this manual for typical starting calibration factors and enter this value in the Pulse/Unit field.

NOTE: Unit label will vary depending on the unit of measure that has been set up in the Register.

In the calibration screens you will notice that there is a yellow key labeled **Run Calibration**. Pressing this key will begin the actual calibration process by performing the meter screen test and resetting the delivery volume to 000.000. At the same time, the Register will provide the permissive signal to the valve output to allow flow through the meter.

NOTE: All deliveries in the calibration mode have a resolution to the thousandths decimal place allowing for very precise calibration.

Flow product into or through the proving device at the normal (nominal) operating flow rate for the meter until the desired calibration volume is reached. When calibrating the flow meter, it is recommended that the calibration volume be greater than or equal to the high end flow rate rating of the metering device (100 GPM = Minimum 100 Gallon prover).

Once the desired calibration volume is reached, pressing the **End** button will return the Register back to the calibration menu screens. Navigate the selection bar to the **Prover** quantity field, and press **OK**. Enter the exact volume to the greatest detail that was registered on the proving device, then press **OK**. At this point, the Register will calculate the percent of error between the prover and register, and automatically adjust the Pulses/Unit accordingly.

Repeat this process until the Register register is within local Weights and Measures tolerance or company regulations. Once all calibrations are made and setup is complete, tighten the calibration bolt on the side of the Register housing. If a ticket printer is connected and a final calibration ticket is desired, insert a ticket before exiting calibration mode and a ticket will print when prompted.

Multi-point Calibration

Multi-point calibration is used to improve the accuracy of a flow meter across its full rated flow rate range, resulting in a much flatter accuracy curve. Accuracy of a flow meter tends to lessen at lower flow rates however repeatability of the meter remains consistent. A meter might not be perfectly accurate at low flow rates, but it is inaccurate by the same amount each time. Multi-point calibration takes advantage of the steadfast repeatability of a Liquid Controls meter by identifying the amount of inaccuracy and correcting it with a linearizing algorithm during deliveries. In order to apply the linearizing algorithm, the degree of error for points along the accuracy curve must be identified by making a number of deliveries at different flow rates into a volumetric prover. Multi-point calibration is very beneficial for meter systems that experience a wide range of flow rates (for example, trucks that fill tanks of varying sizes) and for meter systems that have recently undergone maintenance or other alterations that could change the accuracy curve itself.

To begin the multi-point calibration process, ensure the Register is in the calibration mode by removing any existing seal wire and loosening the calibration bolt on the side of the register

housing approx 5-6 turns. If a ticket printer is connected to the Register, make sure a ticket is in place and the printer is ready. If connected, the register will print a calibration ticket showing the current calibration as well as any existing multi-point calibration information of the register. If no ticket printer is connected or the calibration ticket is not desired, press the **Abort** key to skip the print process.

Before starting the process of multi-point calibration, ensure that the initial single point calibration has been completed and the meter is accurate and repeatable. All multi-point factors are based on this initial calibration.

Once in the calibration mode, select **Calibration** from the main menu to access the calibration screens. Scroll to Calibration screen 4/4 to access the multi-point calibration fields.

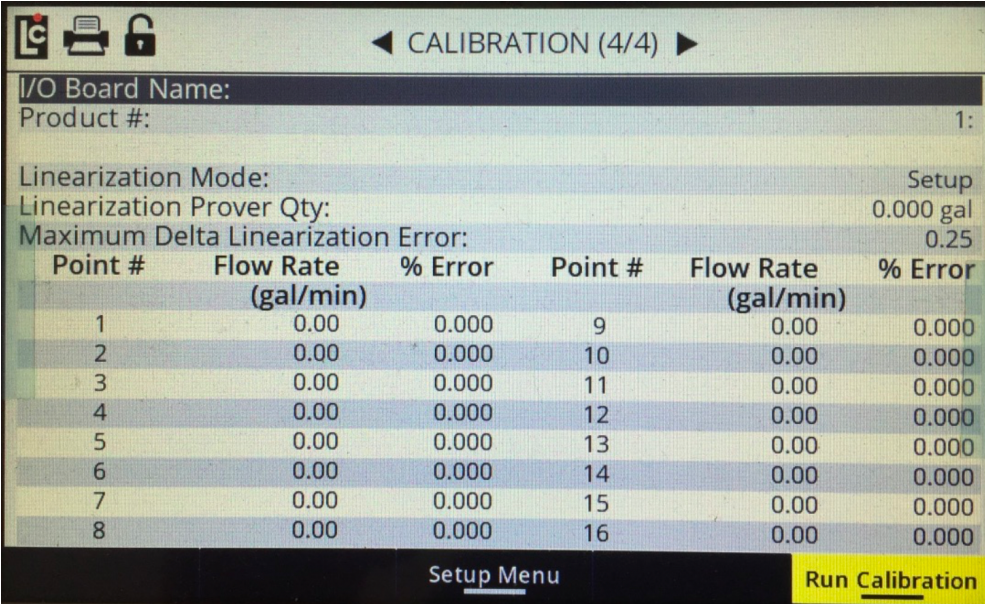

CALIBRATION (4/4)					
I/O Board Name:					
Product #: 1:					
Linearization Mode:					Setup
Linearization Prover Qty:					0.000 gal
Maximum Delta Linearization Error:					0.25
Point #	Flow Rate (gal/min)	% Error	Point #	Flow Rate (gal/min)	% Error
1	0.00	0.000	9	0.00	0.000
2	0.00	0.000	10	0.00	0.000
3	0.00	0.000	11	0.00	0.000
4	0.00	0.000	12	0.00	0.000
5	0.00	0.000	13	0.00	0.000
6	0.00	0.000	14	0.00	0.000
7	0.00	0.000	15	0.00	0.000
8	0.00	0.000	16	0.00	0.000

Setup Menu Run Calibration

In the **Calibration** screen 4/4, notice the yellow key labeled Run Calibration. Press this key to begin the actual calibration process by performing the meter screen test and resetting the delivery volume to 000.000. At the same time, the Register will provide the permissive signal to the valve output to allow flow through the meter.

NOTE: All deliveries in the calibration mode have a resolution to the thousandths decimal place allowing for precise calibration.

Begin to flow product into or through the proving device, ensuring that the metering system is delivering at the flow rate for the desired multi-point calibration point.

Once the desired multi-point calibration volume is reached, pressing the **End** button will return the Register to the Calibration menu screen 4/4. Navigate the selection bar to the Linearization Prover Quantity field, and press **OK**. Enter the exact volume to the greatest detail that was registered on the proving device, then press **OK**. The Register will automatically display a prompt to select which of the 16 available multi-point fields to perform the calibration. Next the Register will display a prompt to the flow rate of the previous delivery. Enter the flow rate that was used for the multi-point calibration that was just performed. At this point, the Register will calculate the percent of error between the prover and register for the multi-point and automatically add the % error amount. When complete, the screen will show the point on the screen—together with the flowrate and % error.

Repeat this process, ensuring that the calibration process is accurate, repeatable and within local Weights and Measures tolerance—or company regulations. Repeat this process for each of the different multi-point calibration flow rate points that are desired.

When setting up the linearization points, you can specify the maximum difference allowed between adjacent linearization points. While most metrological jurisdictions require a maximum of 0.25% error between adjacent flow rates, this value can be changed to a value within the range 0.00 - 1.00. This value is protected by the W&M seal on the register.

Follow these steps:

1. Select the **Maximum Delta Linearization Error** field and press the **OK** key.
2. Enter a value in the range [0.00, 1.00] and press the **OK** key.

NOTE: When sorted by flow rate, the delta error between two adjacent linearization points will be validated when the **Linearization Mode** field is set to **Applied**.

Once all multi-point calibrations are complete, you must apply multi-point calibration. To do this, you must ensure that the difference between adjacent multi-point flow rate errors does not exceed +/- .25% or the Register will not allow you to apply multi-point. If all adjacent % error points are within this range, change the **Linearization** mode setting from **Setup** to **Applied**. If within tolerance, the field will remain at **Applied**. If out of tolerance, this field will toggle back to

Setup and require additional low rate points to further improve the linear accuracy with the +/- .25% range.

Once all multipoint calibrations are made and linearization has been applied, tighten the calibration bolt on the side of the Register housing. If a ticket printer is connected and a final calibration ticket is desired, insert a ticket before exiting calibration mode and a ticket will print when prompted.

Setting the S1 Close time

Setting the S1 closure time properly is an important part of the setup process when using a 2-stage preset valve. If this value is not set correctly, it may cause the Register to over or under shoot the desired preset volume or cause long delays in reaching the final preset amount. S1 closure rates will depend on the flow rate of the system as well as the viscosity of the product.

A 2 stage preset valve is designed to allow a soft closure of the valve by transitioning from high flow, to low flow before reaching final closure. This process greatly improves the ability of the preset to stop at the exact volume desired. For the most accurate closure, it is best that once the transition from high flow to low flow is made, the flow rate should stabilize at the low flow rate for a few seconds before the final closure is reached.

The best way to figure out a proper setting for the S1 field is to set up the register for a normal, non preset delivery, and then begin flow at the normal operating flow rate. Once at a normal flow rate, press the **Stop** button on the register and watch the register closely to see how many units are measure between normal flow to a full stop. This will help to determine how many units of measure it takes to close the valve fully. Repeat this process two more times and find the average close time.

Next, take the normal flow rate of the meter, calculate 2% of this number (for example, 2% of 100GPM = 2 units), then add this value to the valve close time. This number should represent a closure time that is not too long or too short for the user and allow for accurate preset volumes.

Here's an example: The valve close time of 2 gallons + 2% of normal flow rate is 2 GPM = 4 units to be set in S1 close field.

Enter the calculated value into the S1 close time field and give the system a final test to ensure the Register is now presetting accurately. If you find that the closure time is to long, minor adjustments can be made to the S1 closure.

If you see that the unit is not presetting accurately, or it is over or under-shooting, then increase the S1 closure until the issue is resolved or consult with a Liquid Controls factory trained technician.

Setting up delivery ticket options

Setup of a delivery ticket on the Register can primarily be completed in the Register screen 3/3. In this screen, the base ticket format can be selected as well as additional printed lines that are available.

The Register has incorporated the 4 most common ticket formats from the past LCR family of tickets as a baseline for setting up a ticket.

- **Standard Long Form** - This format is based on the original LCR ticket ST200. It contains many details about the Register setup, as well as the metrological data that is required to print on every ticket.
- **Standard Short Form** - This format is based on the available LCR compressed ticket formats ST202, ST208, ST215, ST221, etc. This format was originally designed to fit the small print space of a mechanical ticket for customers that did not want to change their ticket design. The base version of this ticket prints just the minimum required Weights and Measures printed fields.
- **Detailed With Totalizers** - This format replicates the original LCR aviation ticket formats ST210, ST247, ST250. This format contains detailed delivery information as well as prints the start and end accumulative totalizers which is common in aviation and load rack applications.
- **Long Form without Time** - This format replicates ST203.

Print the previous ticket

From the Idle delivery screen, it is always possible to reprint a copy of the transaction ticket for the previous delivery. Press the function key labeled **Print Last Ticket**. Ensure that there is a ticket in place and the Register will issue the reprint command and print the ticket.

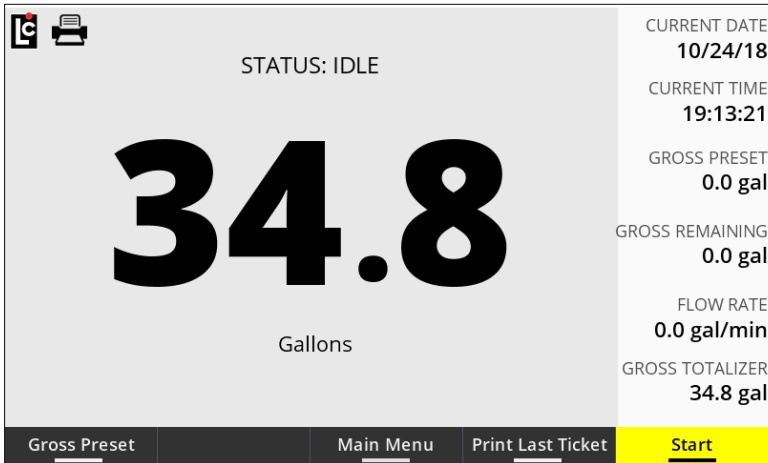

Upgrading the Firmware by USB

Upgrading the Register firmware is straightforward. This guide explains how to upgrade the firmware with a USB drive.

Follow these steps:

1. Obtain the firmware upgrade from the Liquid Controls website (if available) or a factory representative. The firmware will be named SR1000_Vx.xx.xx.deb (x.xx.xx represents the current firmware version number).
2. Use a standard USB flash drive for the upgrade and create a folder on the root of the drive called "Import". (USB\Import).

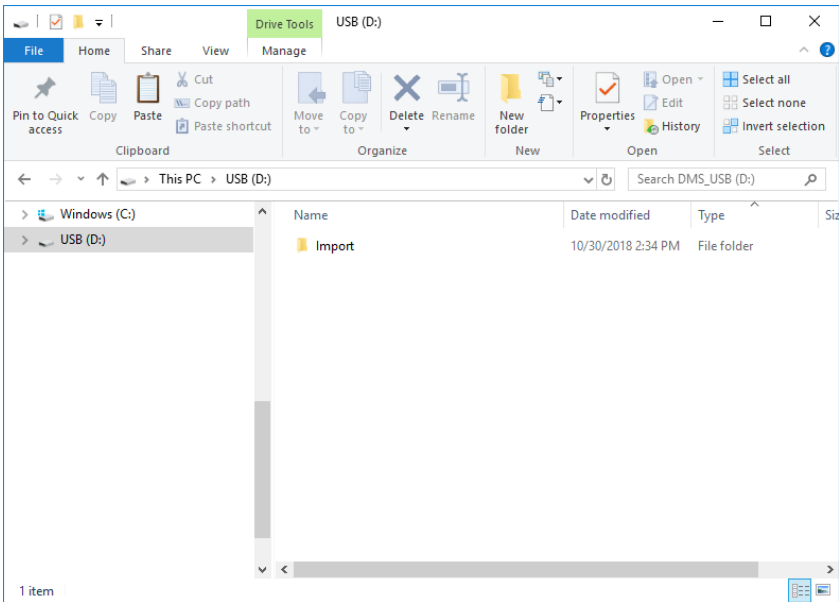

- Copy the firmware from the computer where it was previously saved directly into the **Import** folder on the USB drive.

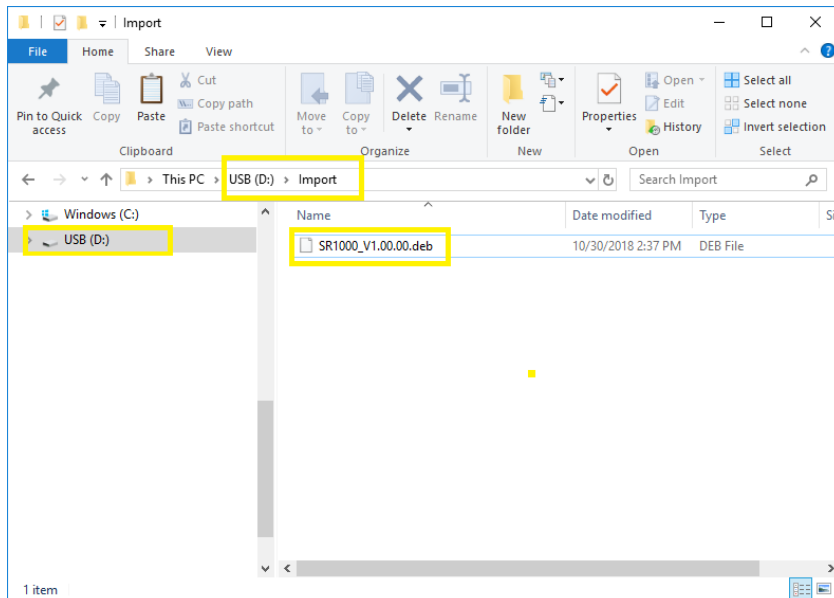

- Remove the USB drive from the computer.
- Insert the USB drive into the USB port on the main circuit board of the Register.
- If power is not already applied to the Register, turn on the power, then continue.
- Loosen the calibration bolt on the side of the Register until the unit is in the calibration mode and the **Main Menu** is displayed.

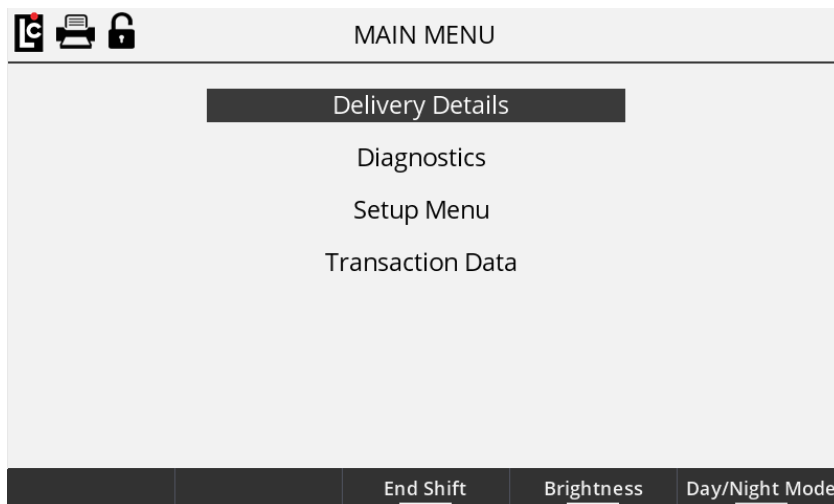

8. Navigate to the **Setup Menu** option and press **OK**.

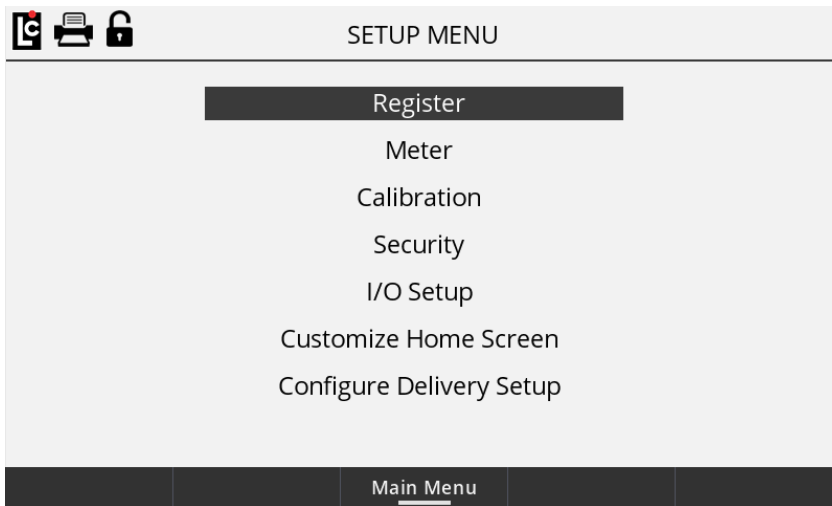

9. Navigate to the **Security** option and press **OK**.

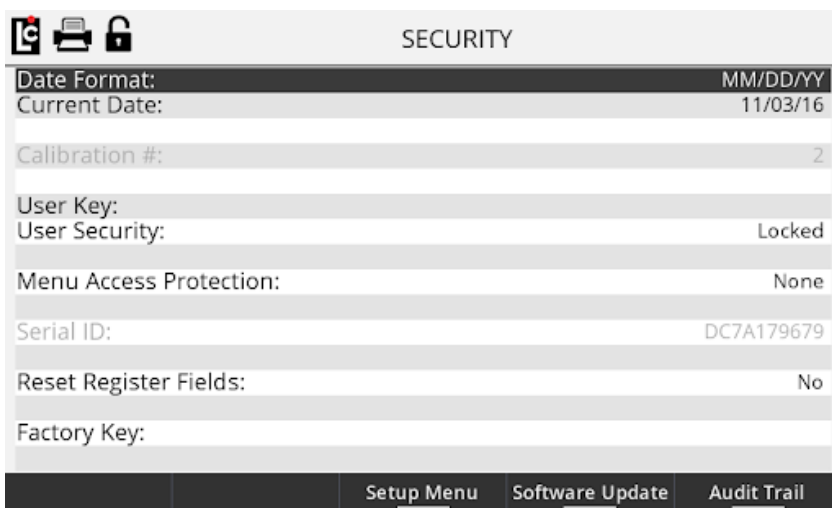

10. Press the function key labeled **Firmware Upgrade**.
11. Select **Copy Files from USB** option and press **OK**. This will copy the firmware from the USB drive to the drive of the Register. However, you must continue to complete the load process. Once loaded, a screen stating **File Load was successful** should appear, then press **OK**.
12. Select **Update (MASTERLOADx.iQ) Firmware** and press **OK**.

13. Select the file to be loaded (SR1000_Vx.xx.xx) and press **OK**. If you have more than one version of firmware saved on the USB drive, make sure you are selecting the most recent version before pressing OK.
14. Once the firmware is loaded, the Register will automatically reboot.
15. Remove the USB drive from the Register once complete.
16. If the Register requires a **Clear All** following the upgrade, a screen will display suggesting that a clear all be done. As necessary, follow the procedure to [Perform a Clear All](#)¹²⁵.
17. If no **Clear All** is necessary, the upgrade should be complete at this time.

Perform a Clear-All Procedure

In some cases it may be necessary to perform a Clear All procedure and reset all of the program settings back to the factory default. This is usually done by a factory trained technician that is upgrading software, transferring a board from unit to unit, or if a memory clear is needed. It is recommended that you save a configuration file of the current program settings or copy all of the settings to a notepad before performing a clear all if you plan to preprogram the unit with the same information.

Follow these steps to perform a clear all:

1. Enter the calibration mode by loosening the calibration bolt on the side of the Register until the **Main Menu** is displayed on the screen.
2. Navigate to the **Setup Menu** and press **OK**.
3. Navigate to the **Security** option and press **OK**.
4. Navigate to **Reset Register Fields** option and press **OK**.
5. Select **Clear All** from the list box that is displayed and press **OK**.
6. A prompt will appear: "Are you sure you want to clear all settings? All settings will revert back to factory defaults including custom settings."
7. To proceed with the clear all, press the **Yes** function key and the clear all process will begin.
8. Once complete, all programmable fields (except Time and Date) will be reset to factory default settings.
9. Reprogram the unit as appropriate.

Print a transaction

The Register is capable of reprinting transaction using the transactions data log screens. The register is able to store a number of transactions in its memory, corresponding with the number of days retained (which is set in the **Logging** setup). The default setting is to retain transaction logs for 365 days before deleting them from memory.

Follow these steps:

1. To reprint a transaction log, press the Main Menu function key to access the main menu.
2. Navigate to the **Transaction Data** option and press **OK**.
3. Use the navigation key pad to scroll between the screen pages or up and down in the screen to select a transaction record. Transaction records are sorted in order by date. Time and sale number are also displayed for quick identification of the record.
4. Select the needed record and press **OK**
5. The transaction information will now be displayed on the screen for review.
6. If the correct record is selected and a printer is connected to the Register, the user can print the transaction data by pressing the **Print** function button.
7. Once the ticket is printed, or if this is not the desired record, press the **Close** function key to return to the transaction list, or press the **Home** button to return to the Home screen.

Setup custom profiles

The Register is capable of displaying and prompting for detailed delivery information that may be useful when making a delivery. Customize Home Screen and Configure Delivery Setup can be used to setup preconfigured or custom delivery detail screens, and setup user prompts that can be used to collect additional transaction information.

Both the Customize Home Screen and the Configure Delivery Setup screens share a profile field. The profile field setting will determine the information that is to be displayed on the delivery screen and in the Delivery setup options. Liquid Controls has included several pre-configured profiles in the Register to help simplify the setup process. Optionally, you can create a custom profile.

Follow these steps to select a profile:

1. Place the Register into the calibration mode and access the Main Menu.
2. Navigate to the **Setup Menu** and press **OK**.
3. Navigate to **Setup Home Screen** option and press **OK**.
4. From either screen 1 (**Customize Home Screen**) or screen 2 (**Configure Delivery Setup**) the user can select the desired profile from the profile field.

Follow these steps to set up a custom profile (**Customize Home Screen**):

1. Select **Custom** from the **Profile** field list box and press **OK**.
2. Setup the left and right columns in **Customize Home Screen** by using the navigation keys to move the selection bar up and down to the desired column and line number, and press **OK**.
3. Select the desired field to be displayed in that location from the list box and then press enter.
4. The selected item should now be displayed in the **Customize Home Screen** in the desired location.
5. Continue setting up any desired locations with options as needed remembering that it is good practice to keep like items grouped together on the screen for easy viewing by the user.

Follow these steps to set up a custom profile (**Configure Delivery Setup**):

1. Navigate to the **Configure Delivery Setup** screen by pressing the left or right navigation keys.
2. Select the **Custom** profile from the **Profile** list box and press **OK**.
3. Use the navigation keys to scroll to Prompt 1 and press **OK**.
4. Select the desired first prompt from the **Edit Fields** list box remembering that it is good practice to setup the prompts in a logical order that makes sense for the user.
5. Repeat this step for each additional prompt that is desired when making a delivery.

Print a diagnostic ticket

Printing a diagnostic ticket is very simple with the Register.

Follow these steps:

1. From the home screen, press the Main Menu key to access the main menu options.
2. Navigate to the **Diagnostics** menu option and press **OK**.
3. Ensure you have a ticket in the printer, then press the **Print Diagnostic** key.

At this point, the Register will print the current diagnostic ticket. Below is an example of a calibration ticket. The number of products that will print out will depend on the number of calibrations that have been set up on the register.

```

CALIBRATION TICKET #          12
CALIBRATION EVENT #          9
CONFIGURATION EVENT #        8
CALIBRATION DATE 11/15/18 14:15:12
METER IDENTIFIER             555214
SERIAL NUMBER                DC7A179679
CALIBRATION NUMBER 1         LPG
  COMP TYPE                   TABLE 24
  SG                          0.500
PULSES/GALLON                2189.125200
TOTAL GROSS                   212354.4 GALLONS
TOTAL NET                     210354.1 GALLONS
SR1000 FIRMWARE              V0.01.00
SR1010 FRIMWARE              V0.01.00
TEMPERATURE                   63.81 DEG. F
TEMP ZERO                     0.00 DEG. F
PULSER FAULTS                 0
FLOW DIRECTION                ->
LCR NODE ADDRESS              250

```

```

CALIBRATION TICKET #          12
CALIBRATION EVENT #          9
CONFIGURATION EVENT #        8
CALIBRATION DATE 11/15/18 14:15:12
METER IDENTIFIER             555214
SERIAL NUMBER                DC7A179679
CALIBRATION NUMBER 1         GASOLINE
  COMP TYPE                   NONE
  NONE                         0
PULSES/GALLON                2184.125200
TOTAL GROSS                   212231.4 GALLONS
TOTAL NET                     0.0 GALLONS
CALIBRATION NUMBER 2         DISTILLATE
  COMP TYPE                   NONE
  NONE                         0
PULSES/GALLON                2180.122200
TOTAL GROSS                   132231.4 GALLONS
TOTAL NET                     0.0 GALLONS
CALIBRATION NUMBER 3         LUBE OIL
  COMP TYPE                   NONE
  NONE                         0
PULSES/GALLON                2103.324200
TOTAL GROSS                   12122.4 GALLONS
TOTAL NET                     0.0 GALLONS
SR1000 FIRMWARE              V0.01.00
SR1010 FRIMWARE              V0.01.00
TEMPERATURE                   63.81 DEG. F
TEMP ZERO                     0.00 DEG. F
PULSER FAULTS                 0
FLOW DIRECTION                ->
LCR NODE ADDRESS              250

```

Water Detector Setup for I/O Board

Hardward Interfaces

- LCR.iQ Register
- I/O Board – Rev. J or greater
- SENSEiQ board (optional)

- Faudi Water Detector (or equivalent)

Basic Electrical Requirements

See hardware installation instructions.

Software Interfaces

4-20mA Analog Input

Setup

Follow these steps to setup the Water Level feature of the LCRiQ register:

Step 1 - Enter the Register Calibration mode by rotating the W&M screw counterclockwise.

Step 2 - Enable the Water Sensor service.

- Open the I/O Setup screen in the Setup Menu.
- Open the Services screen by pressing the **Services** hot key.

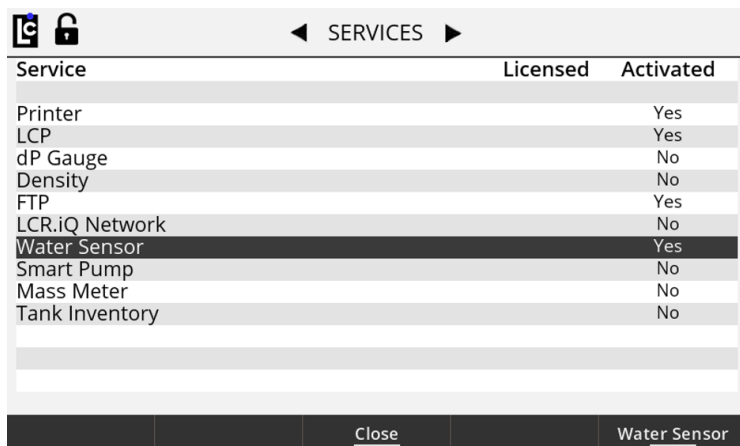

Service	Licensed	Activated
Printer		Yes
LCP		Yes
dP Gauge		No
Density		No
FTP		Yes
LCR.iQ Network		No
Water Sensor		Yes
Smart Pump		No
Mass Meter		No
Tank Inventory		No

At the bottom of the screen, there are two buttons: Close and Water Sensor.

- Select the **Water Service** field by pressing the Up or Down keys, and then press Enter.
- Select **Yes** and press the **OK** key.

- Open the Sensor Setup screen by pressing **Sensor Setup** hot key.

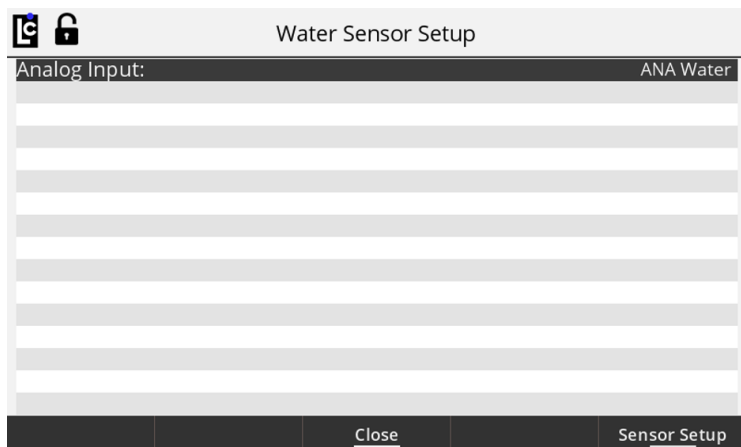

Step 3 - Setup the Water Service parameters for the Analog Port of the I/O or SENSEiQ board to which the water sensor connects. The water sensor uses the 4-20 mA current loop for operation. The register fields for the water sensor operation are accessible from Water Sensor Setup screen. Optionally, the water sensor configuration fields are accessible from the I/O Setup screen 3 for I/O board-or from I/O Setup screen 7 for the SENSEiQ board.

- Press the **OK** key and select desired analog input from the displayed list by pressing Up or Down keys. Select **Analog ANA** for the sensor connected to the I/O board, or **ANA11** through **ANA16** for sensor connected to SENSEiQ board. Press the **OK** key.

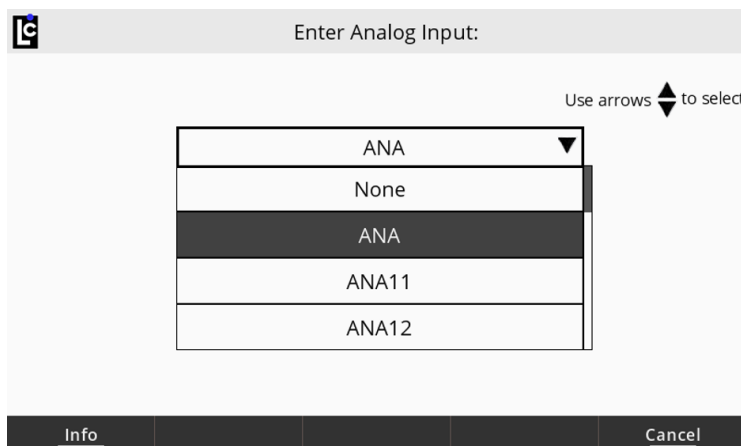

- Open the I/O Analog Input Setup screen by pressing the **Sensor Setup** hot key.

I/O Analog Input Setup	
Sensor Type:	Water Sensor
Name:	ANA Water
Unit of Measure:	ppm
Minimum Raw mA Value Supported:	4.0 mA
Maximum Raw mA Value Supported:	20.0 mA
< 4.0mA	None
> 20.0mA	None
4.0mA is	0 ppm
20.0mA is	0 ppm
Analog Error Delay:	10 sec
Print Low Value on Delivery Ticket?	No
Print High Value on Delivery Ticket?	No
Print Average Value on Delivery Ticket?	No
Close Trigger Setup	

- Enter the **Name** of the input and press the **OK** key.
- Select the **Unit of Measure** field, and then select **PPM** as a unit of measure to be used for water level detection.
- Activate the alarm actions when the analog input current is out of the required range. To activate the alarm, select the **<4mA or >20mA** field and choose **Error** from the drop-down list. Press the **OK** key.
- Set the water level associated with a 4mA input current: Select the **4mA** field, press the **OK** key, and then set the value of the water level, for example, to 0. Press the **OK** key.
- Set the water level associated with a 20mA input current: Select the **20mA** field, press the **OK** key, and then set the value of the water level, for example, to 50. Press the **OK** key.
- Set the time in seconds required for the water level to continuously be at the selected level before the alarm actions will be activated. Select the **Analog Error Delay** field, press the **OK** key, and enter the time in a range from 0 to 10 seconds. Press the **OK** key.
- Choose which water levels that are detected during delivery will print on the delivery ticket. The average, low, or high levels can be printed by selecting the **Yes** options for those fields. Typically, high is set to **Yes**, and average and low are set to **No**.
- Open the I/O Analog Trigger Setup screen by pressing **Trigger Setup** hot key.

Trigger	Threshold	Action	Output
None			
None			
None			
None			

Sensor Type: Water Sensor

Close

- Set the parameters of the first trigger to be used to monitor the water level during delivery:
 - Select the first trigger field and press **OK** key.
 - Specify if an action must occur when the water level is above or below the corresponding trigger level. Select the **Above** option from the drop-down list and press the **OK** key.
 - Enter a trigger threshold of **15** and press the **OK** key.
 - Select the delivery action to be taken when the trigger occurs. Select the **Stop** option from the drop-down list and press the **OK** key.
 - Select the Digital Output of the I/O board to be used with the trigger: Outputs from 1 to 6 can be used. Ensure that the selected output has not been used for different actions of the register. Use the drop-down list to select the desired output.
- Set the parameters of the second trigger to be used to monitor the water level during delivery:
 - Select the second trigger field and press **OK** key.
 - Specify if an action must occur when the water level is above or below the corresponding trigger level. Select the **Above** option from the drop-down list and press the **OK** key.
 - Enter a trigger threshold of 30 and press the **OK** key.
 - Select the delivery action to be taken when the trigger occurs. Select the **End** option from the drop-down list and press the **OK** key.
 - Select the Digital Output of the I/O board to be used with the trigger. The output should be the same as the one selected for the first trigger.
- If desired, select and configure another trigger. Up to 4 different triggers can be configured for the Analog Input of the I/O board.

- Complete the Analog Input Setup by pressing the **Close** hot key.

Appendix A: K-Factor (Pulse/Unit) Chart

Approximate K-Factors and Volumetric Reference Data									
The K-Factor (Pulses/Unit) values listed below are for reference only when initially calibrating a specific meter model and are not to be used as a final K-Factor.									
<small>(All Liquid Controls meter models listed below assume use of the 400ppr pulser with a 1:1 Packing Gland/Face Gear ratio when calculating the Pulses/Unit. For 2:1 ratio, divide the Pulses/Unit by 2)</small>									
	Meter Model	pulses/gal	max gal/min	revs/gal	gal/rev	pulses/L	max L/min	revs/L	L/rev
Liquid Controls M & MA Series	MA-4	4894.8	30	12.2370	0.0817	1293.21	225	3.2330	0.3093
	M-5, MA-5	4894.8	60	12.2370	0.0817	1293.11	225	3.2328	0.3093
	M-5, MA-5 (3:1 Internal gearing)	1631.6	60	4.0790	0.2452	431.07	225	1.0777	0.9279
	M-7, MA-7	2222.0	100	5.5550	0.1800	587.05	380	1.4676	0.6814
	M-10	2222.0	150	5.5550	0.1800	587.05	550	1.4676	0.6814
	M-15, MA-15	823.2	200	2.0580	0.4859	217.49	760	0.5437	1.8392
	M-25	823.2	300	2.0580	0.4859	217.49	1140	0.5437	1.8392
	M-30	296.8	350	0.7420	1.3477	78.41	1325	0.1960	5.1011
	M-40	296.8	450	0.7420	1.3477	78.41	1700	0.1960	5.1011
	M-60 (New Style)	159.3	600	0.3983	2.5107	42.09	2270	0.1052	9.5029
M-60 (Old Style)	101.8	600	0.2545	3.9293	26.90	2270	0.0672	14.8723	
M80	159.3	800	0.3983	2.5107	42.09	3030	0.1052	9.5029	
Liquid Controls MS Series	MS-7	2222.0	100	5.5550	0.1800	587.05	380	1.4676	0.6814
	MS-15	823.2	200	2.0580	0.4859	217.49	760	0.5437	1.8392
	MS-25	823.2	350	2.0580	0.4859	217.49	1140	0.5437	1.8392
	MS-30	296.8	350	0.7420	1.3477	78.41	1325	0.1960	5.1011
	MS-40	159.3	450	0.3983	2.5107	42.09	1700	0.1052	9.5029
	MS-75	101.8	700	0.2545	3.9293	26.90	2650	0.0672	14.8723
	MS-120	63.2	1000	0.1579	6.3331	16.69	3780	0.0417	23.9709
Avery Hardoll BM & DM Series	BM250 (Single Capsule)	666.8	300	1.6670	0.5999	176.17	1140	0.4404	2.2705
	BM950 (Single Capsule)	666.8	362	1.6670	0.5999	176.17	1370	0.4404	2.2705
	BM350 (Dual Capsule)	333.5	660	0.8337	1.1995	88.11	2050	0.2203	4.5400
	BM450 (Dual Capsule)	333.5	542	0.8337	1.1995	88.11	2280	0.2203	4.5393
	BM550 (Dual Capsule)	333.5	602	0.8337	1.1995	88.11	2500	0.2203	4.5400
	BM650 (Triple Capsule)	222.3	793	0.5558	1.7992	58.74	3000	0.1468	6.8100
	BM750 (Triple Capsule)	222.3	793	0.5558	1.7992	58.74	3000	0.1468	6.8120
	DM	263.3	660	0.6583	1.5191	69.57	2500	0.1739	5.7504

Liquid Controls recommends that any meter-mounted register driven by the packing gland/face gear assembly uses the 1:1 Ratio for the highest resolution.
Max flow rates listed above may vary depending on the meter class and regulatory approval.

Appendix B: Data Types

For data types D, F, SI, SL, SS, UI, UL, US, and V, the least significant byte of the data is stored at the lowest address with each subsequent byte being stored at the next incremented address. For example, a two byte unsigned short equal to 1,000 and placed at offset 4 in a message or record would be stored as an E8h at offset 4 and a 03h at offset 5.

Type	Name	Description
A	ASCII Character	Contains a one byte ASCII character. The number of characters stored in the field is Size .
AZ	ASCIIZ String	Contains a NUL terminated string of ASCII characters. The maximum length of the string is Size-1 .

B	Boolean	Contains a Boolean value of TRUE or FALSE.
D	Double Floating Point	Contains an eight byte floating point number in IEEE-754 format.
F	Floating Point	Contains a four byte floating point number in IEEE-754 format.
LF	LCR Flow Rate	Contains a signed four byte integer in the range -2147483648 to 2147483647 with an implied decimal point defined by the decimals field in the record.
LL	LCR List	Contains a one byte unsigned integer in the range of 0 to 255.
LV	LCR Volume	Contains a signed four byte integer in the range -2147483648 to 2147483647 with an implied decimal point defined by the decimals field in the record.
SB	Signed Byte	Contains a one byte signed integer in the range -128 to 127.
SI	Signed Integer	Contains a signed integer in which the range is operating system dependent. On 16-bit machines, it is a two-byte signed integer in the range -32768 to 32767. On 32-bit machines, it is a four-byte signed integer in the range -2147483648 to 2147483647.
SL	Signed Long	Contains a four byte signed integer in the range -2147483648 to 2147483647.
SS	Signed Short	Contains a two byte signed integer in the range -32768 to 32767.
ST	Structure	Data element is a structure that varies depending on the structure definition.
UB	Unsigned Byte	Contains a one-byte unsigned integer in the range of 0 to 255.
UI	Unsigned Integer	Contains an unsigned integer in which the range is OS-dependent. On 16-bit machines, it's a two byte unsigned integer in the range 0 to 65535. On 32-bit machines, it's a four byte unsigned integer in the range 0 to 4294967295.
UL	Unsigned Long	Contains a four byte unsigned integer in the range 0 to 4294967295.
UN	Union	Data element is a union. The contents vary with the union definition.
US	Unsigned Short	Contains a two-byte unsigned integer in the range 0 to 65535.



LIQUID CONTROLS®

An IDEX Energy & Fuels Business



105 Albrecht Drive
Lake Bluff, IL 60044-2242
1.800.458.5262
1.847.295.1050
Fax: 1.847.295.1057
www.LCmeter.com

© 2017 Liquid Controls
LC_IOM_ONTHEGOWIFIADAPTER V1: 05/17